

# ARCHITECTURAL DESIGN CRITERIA

## TABLE OF CONTENTS

<b>I</b>	GENERAL .....	<b>4</b>
<b>II</b>	CRITERIA.....	<b>5</b>
	<b>A. SITE REQUIREMENTS.....</b>	<b>5</b>
	1. SITE DESIGN.....	5
	2. VEHICULAR ACCESS AND OFF-STREET PARKING .....	6
	3. COVERED WALKWAYS AND METAL CANOPIES.....	6
	4. SITE FURNISHINGS.....	6
	5. HANDRAILS/GUARDS (IN OPEN COURTYARD AREAS).....	6
	<b>B. OUTDOOR ATHLETIC AND PLAY FACILITIES .....</b>	<b>7</b>
	1. SEE CIVIL DESIGN CRITERIA – PLAY AND SPORTS FIELDS .....	7
	<b>C. BUILDING REQUIREMENTS.....</b>	<b>8</b>
	1. MATERIALS .....	8
	2. GENERAL REQUIREMENT .....	8
	3. FULLY SPRINKLER ALL NEW BUILDINGS.....	8
	4. BUILDINGS AND ENTRY .....	8
	5. BUILDING CIRCULATION .....	8
	6. BUILDING(S) AND ENERGY .....	9
	7. EXTERIOR DOORS.....	9
	8. HORIZONTAL SURFACES .....	9
	9. ACOUSTICAL PERFORMANCE AND SOUND TRANSMISSION.....	9
	10. WALLS .....	10
	11. CEILINGS .....	10
	12. GOLF CART STORAGE/CHARGING AREA.....	10
	13. KITCHENS, CUSTODIAL RECEIVING, CUSTODIAL CLOSETS, FLAMMABLE STO., CHEMICAL STO., CULINARY ART LAB	
	KITCHENS.....	10
	14. TOILET ROOMS, SHOWERS, AND CHANGING/BATHING AREAS.....	11
	15. MAIN ELECTRICAL ROOM .....	11
	16. ELECTRICAL ROOMS – NOT THE MAIN ELECTRICAL.....	12
	17. CHEMICAL SCIENCE STORAGE ROOM.....	12
	18. SCIENCE ROOM EMERGENCY SHOWER/EYEWASH .....	12
	19. ADMINISTRATION SUITE .....	12
	20. DATA/COMMUNICATION ROOMS.....	12
	21. SHOPS.....	12
	22. EXTERIOR HANDRAILS.....	12
	23. PLATFORMS AND STAGES .....	13
	<b>D. CASEWORK/CABINETS .....</b>	<b>13</b>
	<b>E. THERMAL AND MOISTURE PROTECTION .....</b>	<b>13</b>
	1. WATERPROOFING AND VAPOR BARRIERS .....	13
	2. INSULATION .....	13
	3. FIREPROOFING AND FIRE STOPPING/FIRE BLOCKING .....	13
	4. JOINT SEALERS (TILT-UP WALLS) .....	14
	5. ROOFING.....	14

6.	FLASHING, GUTTERS, DOWN SPOUTS, AND OTHER ACCESSORIES .....	15
7.	ROOF SPECIALTIES AND ACCESSORIES .....	15
<b>F.</b>	<b>DOORS AND WINDOWS .....</b>	<b>16</b>
1.	GENERAL .....	16
2.	DOORS AND FRAMES .....	16
3.	WINDOWS .....	17
4.	FINISH HARDWARE .....	18
5.	GLAZING .....	20
<b>G.</b>	<b>FINISHES .....</b>	<b>20</b>
2.	FLOOR FINISHES .....	20
3.	WALL FINISHES .....	23
4.	CEILING FINISHES .....	24
5.	PAINT FINISHES .....	25
<b>H.</b>	<b>SPECIALTIES .....</b>	<b>25</b>
1.	INSTRUCTIONAL BOARDS .....	25
2.	TOILET PARTITIONS AND PRIVACY SCREENS .....	25
3.	EXTERIOR WALL LOUVERS .....	25
4.	FLAGPOLES .....	25
5.	SIGNS .....	26
6.	LOCKERS .....	28
7.	FIRE EXTINGUISHERS .....	29
8.	METAL SHELVING IN AREAS AS INDICATED IN ED SPECS .....	30
9.	TOILET ROOM ACCESSORIES .....	30
10.	DUST CONTROL – WOODSHOPS AND SIMILAR AREAS .....	30
11.	WIRE MESH PARTITIONS AND DOORS .....	30
12.	OPERABLE PARTITIONS .....	30
13.	Drinking Fountains and Bottle Filling Stations .....	29
<b>I.</b>	<b>EQUIPMENT .....</b>	<b>31</b>
1.	APPLIANCES .....	31
2.	ATHLETIC EQUIPMENT .....	31
3.	GYMNASIUM DIVIDERS .....	31
4.	ASSISTIVE LISTENING SYSTEMS .....	31
<b>J.</b>	<b>FURNISHING .....</b>	<b>31</b>
1.	AUDITORIUM SEATING .....	31
2.	TELESCOPING BLEACHERS .....	31
<b>K.</b>	<b>SPECIAL CONSTRUCTION .....</b>	<b>32</b>
1.	HIGH SCHOOL STADIUMS .....	32
2.	PORTABLE EXTERIOR BLEACHERS .....	33
<b>L.</b>	<b>CONVEYING SYSTEMS .....</b>	<b>33</b>
1.	GENERAL .....	33
2.	PASSENGER ELEVATORS .....	33
3.	WHEELCHAIR LIFTS .....	34

## APPENDIX

SOUND RATINGS.....	35
MOUNTING HEIGHTS .....	36
CEILING HEIGHTS AND TYPE.....	37
PRE-K AND ELEMENTARY SCHOOL APPLIANCES .....	38
MIDDLE SCHOOL APPLIANCES.....	39
HIGH SCHOOL APPLIANCES .....	40
ROOF DRAINAGE CALCULATIONS / PROCEDURE.....	40

## ARCHITECTURAL DESIGN CRITERIA

### I GENERAL

- A. The Design Professional shall use this document in conjunction with the District Master Specifications (DMS) to develop the design and contract documents.
- B. The Design Professional shall coordinate the work under this section with Civil, Electrical, Mechanical, Plumbing, and Structural Design Criteria.
- C. The Design Professional is encouraged to incorporate elements of the following in their designs:
  - 1. Safe school design principles using “Crime Prevention through Environmental Design” (CPTED), Florida Safe School Design Guidelines, and Standard For An Active Shooter/Hostile Event Response (ASHER), NFPA 3000.
  - 2. Standard for an Active Shooter / Hostile Event Response (ASHER) (NFPA 3000).
  - 3. Use recycled products when practical and economically feasible, such as recycled plastic wheel stops or crushed recycled concrete road base.
- D. Goals:
  - 1. Design the project to meet a nationally recognized high-performance green building rating system as approved by the Department of Management services. Such approved systems include the:
    - a. United States Green Building Council, Leadership in Energy and Environmental Design (LEED).
    - b. Green Building Initiative’s Green Globes rating system.
    - c. Florida Green Building Coalition Standards.
    - d. International Green Construction Code.
  - 2. Establish performance-oriented design standards to improve the function, appearance, and safety of the school campus.
  - 3. Establish design guidelines that address architectural elements, building placement, tree preservation and “fit” within the community.
  - 4. Make a positive and memorable statement to students, faculty, visitors and the community.
  - 5. Be sensitive to existing neighbors and community.
  - 6. Promote public health, safety, welfare and “love of learning”.
- E. This division contains requirements for the following elements.
  - 1. Site Requirements
  - 2. Outdoor Athletic and Play Facilities
  - 3. Building Requirements
  - 4. Casework/Cabinets
  - 5. Thermal and Moisture Protection
  - 6. Doors and Windows
  - 7. Finishes, Floor, Wall, and Ceiling
  - 8. Specialties
  - 9. Equipment
  - 10. Furnishing
  - 11. Special Construction
  - 12. Conveying Systems
- F. The Architect, or professional as defined by the Contract with the District, is the person responsible for the design and development of all project documents and the coordination of all consultants' documents.
  - 1. In some case maybe a Professional Engineer, Construction Manager, or General Contractor.

- G. Design shall incorporate the latest design requirements and/or code requirements contained in the following;
  - 1. Florida Building Code (FBC)
  - 2. Florida Fire Prevention Code (FFPC), NFPA 101 the Life Safety Code
  - 3. District Master Specs (DMS)
  - 4. State Requirements for Educational Facilities (SREF).
  - 5. District Design Criteria Elements (architectural, civil, structural, plumbing, mechanical, electrical)
- H. Provide submittals with documentation as listed in procedure BD-001 – Submission for Project Documents and BD-020 – Electronic Plan Submittal.
- I. The Criteria shall not limit or restrain the performance and liability of the Professional or Professionals responsible for the integrity and performance of the structure.
- J. The Criteria is applicable to new construction and to the remodeling and renovation of existing facilities.
- K. The use of the Criteria in this document does not exempt the Design Professionals from any federal or state code or standards controlling the design and construction of any Facility.
- L. Variance/Change Requests shall be provided per procedure BD-007.
  - 1. Variance/Change Requests apply only to District Design Criteria / District Master Specifications.
- M. On campus plans containing multiple buildings, for building identification purposes for construction documents, buildings can be titled as follows; Building 1, Building 2, etc.
  - 1. Multiple building type campuses the electrical power distribution shall be as follows; main primary service shall be to the Main Electrical Room (Switchgear Room), and shall be located in a single building.
  - 2. The distribution to other buildings shall be from the Main Electrical Room (See the Electrical Design Criteria).

## II CRITERIA

### A. SITE REQUIREMENTS

- 1. Site Design
  - a. The site shall function to reinforce the educational philosophy of the schools.
  - b. Site design shall address the relationships of site elements to the building, streets and neighbors; as well as the potential for curriculum development, the reduction of municipally supplied potable water used for irrigation, reducing the urban heat island effect and constructing healthier, more energy and resource efficient site plans.
  - c. Site design shall maximize the use of the available site area.
  - d. Exterior and interior walking surfaces shall have slip resistant finishes.
  - e. Design the site allowing for the development of the program playfields.
    - 1) Orient and locate playfields, parking, service drives, drop-off zones, and bus loading zones to reduce the cost of construction, and facilitate connecting of program elements without requiring pedestrians to cross vehicular traffic lanes.
  - f. The site shall comply with CPTED, Florida Safe School Design Guidelines, and NFPA 3000.
  - g. The A/E shall work with the District Planning staff in coordinating local zoning requirements with the District requirements and goals.
    - 1) Coordinate building setback requirements with the Section 453 FBC and local authority having jurisdiction.
  - h. Provide a design, which accommodates space for future classrooms for growth or classroom reduction (Permanent or relocatable type construction) with appropriate utility connections.

- i. Provide an accessible route(s) connecting accessible buildings, accessible elements and accessible spaces.
  - 1) The accessible route shall extend from the public right of way to the educational facility.
- 2. Vehicular Access and Off-street Parking
  - a. Architect shall coordinate traffic circulation and parking with the District Police, Planning, Program Management, and Civil Engineer.
  - b. Accessible parking spaces shall be dispersed around the site's various parking areas.
  - c. See the Civil Design Criteria for access, circulation, parking requirements, and other vehicle and pedestrian requirements.
  - d. See Electrical Design Criteria for lighting and other electrical requirements.
  - e. Provide fire lanes (identified with pavement markings and post signage) along building fronts at both; parent drop off/pickup and bus loop.
- 3. Covered Walkways and Metal Canopies
  - a. Design covered walkways in conjunction with the building design concept as permanent structures that blend with the overall campus appearance.
  - b. Covered walkways shall provide continuous cover along the entire length of the path they protect, but not cross-vehicular drive lanes, parking lots, or loading or service areas.
    - 1) Extent of walkway coverage shall meet FBC-B 453.
  - c. The covered walkway shall be the width of the walkway (or required width) plus 1foot on each side, minimum 8 feet wide.
  - d. Protect column at all vehicle driveways by placing the raised curb 24 inches from the column.
  - e. Covered walkways shall not extend past the curb into the driveway, unless there is at least 14 foot clearance under the lowest structural element.
    - 1) When possible keep the nearest structural element 6 to 12 inches from face of curb line.
  - f. Provide proper lighting in the canopy system see Electrical Design Criteria for light levels.
  - g. Provide for video surveillance along the canopy system as required by School Police.
  - h. Refer to the Civil Design Criteria for drainage from covered walkways.
  - i. Provide covered exterior walkways connecting student occupied, administration buildings, and accessible walks from parent and bus passenger loading/drop-off zones.
  - j. Florida professional engineer shall design walkway cover systems to withstand wind velocities per ASCE 7, current edition in effect at the time of permitting.
- 4. Site Furnishings
  - a. Bicycle Racks shall comply with these requirements:
    - 1) Locate at the Building entry with direct surveillance from the Administrative suite, coordinate with the District Police.
    - 2) Permanently mount to the concrete paving per manufacturer requirements.
    - 3) Locate the racks to prevent crossing of bicycle traffic with vehicular or pedestrian traffic.
    - 4) Provide chain link fencing enclosure 8 feet high.
  - b. Design/select the site/exterior light fixtures and poles in conjunction with the building design concept also see Electrical Design Criteria.
  - c. Provide one flagpole at a prominent location of the school entrance.
    - 1) Place flagpoles away from pedestrian or vehicular traffic, in locations that won't be an obstacle.
  - d. See the Civil Design Criteria for information on fencing material, height, and location.
- 5. Handrails/Guards (in open courtyard areas)

- a. Top rail component on slope handrails/guards shall have vertical element that deters the ability to slide down the rail (a capped vertical component, spaced 48 inches on center), but at the same time allow for continuous graspable handrail.
- B. OUTDOOR ATHLETIC and PLAY FACILITIES
  - 1. See Civil Design Criteria – Play and Sports Fields

## C. BUILDING REQUIREMENTS

### 1. Materials

- a. Shall be durable, permanent, vandal-resistant, easily maintained, and within the limits set by budget, function, and code.
- b. To the greatest extent possible materials shall be allergy free and non-toxic.

### 2. General requirement

- a. The design of each project shall address the following.
  - 1) Safety of students, faculty, staff and visitors (Florida Safe School Design Guidelines, CPTED, and NFPA 3000).
  - 2) Fulfillment of all programmatic requirements, compliance with applicable elements of the District Design Criteria, District Master Specifications.
  - 3) Enhancement of the instructional process.
  - 4) Campus shall be resistant to unauthorized intrusion at any time, yet provide for the entry of visitors through a control point during normal operating hours.
  - 5) Zoning for different day and evening functions and circulation patterns.
  - 6) Life cycle cost effectiveness.
  - 7) Accessibility according to the current FBC – Accessibility, ADAAG, and 2014 ADA-ABA guidelines.
  - 8) Ease of pedestrian and vehicular circulation within and around buildings.
  - 9) Various District prototype area/space designs are to be implemented on new buildings or when possible on existing buildings.

### 3. Fully sprinkler all new buildings.

- a. Renovations and additions to existing facilities are determined on a project-by-project basis in accordance with the FFPC.

### 4. Buildings and Entry

- a. Shall be inviting with a clear, single, central entry to the facility.
- b. The main entry shall be clearly visible and easily identifiable from all major off site access routes to the school.
- c. Locate administrative offices with a clear view of this entry for ease of surveillance and as a clearly identifiable designation for school visitors.
- d. Limit perimeter openings to those required for Life Safety conformance and necessary for independent public use of the project elements e.g. an auditorium, a gymnasium.
  - 1) These entries should also be visually recognizable and inviting.
  - 2) Coordinate required openings with security and surveillance system requirements.
- e. Provide separate service access to the Food Service/Kitchen area and Custodial Receiving area.
- f. Group all program elements requiring access by service vehicles to minimize traffic.
  - 1) Provide sufficient space for vehicles to maneuver.

### 5. Building Circulation

- a. Orientate circulation to provide efficient, convenient access to all spaces.
- b. Minimize pedestrian congestion at doors, stairs, intersecting corridors, and entrances into large rooms off of corridors.
- c. Recess entry doors into classrooms and other interior rooms off corridors with angled walls in a way that eliminates blind spaces.
  - 1) Or provide wider corridor to swing doors into corridor and meet code requirements.
- d. Provide vision panels in all doors to student occupied spaces.



- e. Design multi-story building to limit the number of elevators required.
  - 1) Elevator required on two stories or more.
- f. Provide impact and abuse resistant materials in all circulation spaces.
  - 1) Finishes shall be cleanable and graffiti resistant.
- g. Elementary school building – provide low and high handrails on stairs and ramps.
  - 1) Low handrail at maximum of 25 inches to top of rail.
  - 2) High handrail at maximum 36 inches to top of the rail
  - 3) Maintain 9 inches minimum between vertical distance between upper and lower hand rail.
- 6. Building(s) and Energy
  - a. Utilize passive energy design principals for maximum efficiency and sustainability.
  - b. Minimize glazing, which allows direct sunlight into the building from the west and southwest.
  - c. Provide natural light to all classrooms.
    - 1) Other student occupied spaces shall be provided with natural light when possible and aligned with the program requirements for that space (e.g. – computer lab).
  - d. Provide natural light to faculty occupied spaces when possible.
- 7. Exterior Doors
  - a. Protect all exterior entry doorways by an overhang or recess with an exterior soffit.
  - b. Minimum protection shall be 4 feet, perpendicular to the plane of the door(s), and 1 foot on each side of the doorjamb, parallel to the plane of the door(s).
  - c. Design exterior soffits to prevent rainwater traveling horizontally on the underside of the soffit.
  - d. Engineer the exterior soffits to resist wind loads per current edition of ASCE 7.
  - e. Architect may use a rain diverter in place of overhang or soffit above Mechanical, storage, electrical, toilet room, and other similar type exterior doors.
  - f. When using the canopy option over an exterior doorway assure the scupper discharge does not create potential slip-hazard condition on the concrete walking surface below.
- 8. Horizontal Surfaces
  - a. Slope all exterior horizontal surfaces to drain away from the building and according to FBC – Building, Section 453, and FBC – Accessibility.
  - b. Design horizontal surfaces to prevent ponding.
  - c. Provide a minimum slope of  $\frac{1}{8}$  inch per foot at, but not limited to:
    - 1) Exterior walkways, stair treads, landings, sidewalks, or other exterior walking surfaces.
    - 2) Parapet tops, exterior windowsills, tops of walls, and slope roofs away from the building.
    - 3) Parking lots, paved courts, receiving areas, passenger drop-offs, and any other paved areas.
    - 4) Chiller Equipment Enclosure (concrete floor slab-drain via floor drains or thru-wall scuppers).
  - d. Exterior and interior walking surfaces shall have textured or other slip-resistant finishes with a maximum cross slope of 2% and slope away from the building.
- 9. Acoustical Performance and Sound Transmission
  - a. As a minimum the construct the walls and openings to STC levels outlined in [Sound Rating](#) table of the appendix.
    - 1) Use volume and geometry to enhance acoustic properties of the space.
    - 2) Suspended acoustic tile ceilings in these spaces shall have a CAC value of 35 or greater and an NRC value of 70% or greater.
    - 3) Wall treatments (acoustical wall panels) and flooring materials to be used in these spaces as necessary, to enhance the acoustic properties of the space.

- b. Substitutions or revisions during construction shall comply with the original acoustical analysis of the space involved, or provide a revised analysis.
- c. Sound-insulate spaces containing noise-producing activities from adjacent spaces as required.
- d. Provide appropriate acoustic treatment to control undesirable noise within occupied spaces.
- e. Provide special attention to large spaces, including auditoriums, music rooms, art labs, media centers, dining spaces, multi-purpose rooms, and mechanical equipment spaces.
- f. Locate acoustical treatment susceptible to damage at least 7 feet AFF or provide protection.
- g. Partitions between corridors and classrooms and between classrooms are to be full-height with gypsum board on both sides.
- h. Integrate design elements to improve the performance of audio enhancement systems.
- i. Integrate design elements to limit sound transmission from mechanical equipment rooms and HVAC duct systems.

#### 10. Walls

- a. Provide details for required fire rated wall assemblies and penetrations through those wall assemblies, such as an UL or GA File test number or other approved testing company's detail.
- b. At the interior face of all exterior concrete or masonry walls of conditioned spaces provide insulation as required to meet the FBC Energy Conservation Code requirements, [see F.2](#) insulation, herein.
- c. Interior wall systems
  - 1) Corridor, stairway, gymnasium and cafeteria partitions/walls shall resist impact and abrasion.
  - 2) All interior walls shall be graffiti and mold resistant in addition to being appropriate for location and use.
  - 3) All wall systems shall provide the appropriate fire rating, smoke rating, and/or sound rating.
  - 4) Metal stud wall framing may be placed at 24" on center (O.C.) when needed to meet STC requirements.
    - a) Studs placed at 24" O.C. shall have sufficient structural capacity to provide strength equal to or better than typical construction at 16" O.C.
- d. Provide corner guards in interior corridors at all outside corners and other high traffic areas.

#### 11. Ceilings

- a. Ceilings in individual and group toilet rooms shall be a continuous hard surface.
- b. All acoustical lay-in type ceilings systems shall be sag, humidity (up to RH 99), and mold resistant.
- c. All ceiling/roof or ceiling/floor penetrations that require a fire rating must be meet all requirements of the FBC – Building, Chapter 7.
- d. Minimum ceiling heights and types table in the appendix.

#### 12. Golf Cart Storage/Charging Area

- a. Locate Golf Cart Storage/Charging Area in a location near the Central Receiving Area.
- b. Provide proper electrical connections for charging of carts, coordinate with Electrical Engineer.
- c. Provide ventilation in room used for the charging of golf carts to prevent concentration of hydrogen level from exceeding 1% of volume; coordinate with Mechanical Engineer.
- d. Locate in an area convenient to exterior and roads or sidewalks.
- e. Provide charging stations and storage capacity.

#### 13. Kitchens, Custodial Receiving, Custodial Closets, Flammable Storage, Chemical Storage, and Culinary Art Lab Kitchens

- a. When buildings containing these spaces are located with a Wellfield Zone (as designated by Palm Beach County) the flooring for these spaces shall be chemical resistance (quarry tile with epoxy grout, epoxy flooring, or urethane flooring).
  - b. For Kitchens, follow the requirements of the District Food Services Department.
14. Toilet Rooms, Showers, and Changing/Bathing Areas
- a. Group toilets should be accessible from the primary function area and made available without causing security breaches of other areas of the campus.
    - 1) If located in the dining area, provide self-closing doors between the vestibule and the dining area.
  - b. General requirements.
    - 1) Avoid locating single use toilet rooms off of the main circulation corridors.
    - 2) Locate toilet rooms conveniently and appropriately throughout the campus, and size the room per FBC requirements based on the occupant use of the room or area, i.e. cafeteria, gymnasium, stadium, and auditorium are all assembly occupancy.
    - 3) Minimum areas requiring facility/staff toilet rooms, kitchen staff, staff dining, teacher planning areas, administration areas, media center, gymnasium, and auditorium.
    - 4) Minimum student areas requiring group toilet rooms' cafeteria, gymnasium, auditorium, stadium area, and media center.
    - 5) Provide toilet room(s) and shower(s) in clinic.
    - 6) Provide a restroom with shower in ESE room(s).
  - c. Elementary Schools Special Requirements below:
    - 1) Provide one boy's and one girl's restroom for each two instructional spaces.
    - 2) Provide one boys' and one girls' accessible student restroom and one staff restroom in the Covered Play Area.
    - 3) Provide student toilet rooms in the Art Room, Media Center Music, and Skills Labs.
      - a) Provide separate facilities for male and female, except single use maybe used when allowed by code.
  - d. Design group toilet rooms with doors, which staff can close as necessary for security and control.
    - 1) Door may have to be on magnetic hold open connected to the fire alarm system.
  - e. All accessible showers shall have fold down or fixed seats meeting FBC – Accessibility requirements.
  - f. Provide permanent bench meeting FBC-Accessibility requirements in all changing rooms, rooms with showers, and locker rooms.
    - 1) Permanent benches are to be anchored to floor slabs, to the maximum extent practicable.
  - g. Provide a changing table in all football stadium toilet rooms.
15. Main Electrical Room
- a. The main electrical room is allowed to use the sprinkler exception of NFPA 13, 8.15.11.3 (2013):
    - 1) This is the room with the main switchgear and the service entrance.
    - 2) All equipment is dry type
    - 3) Room is dedicated for electrical equipment only
    - 4) Room shall have a 2-hour fire rated enclosure, walls, ceiling, and/or floor.
    - 5) Not designed for storage, to have a sign posted inside and outside of the room saying, “NO STORAGE ALLOWED”
  - b. Architect shall coordinate with the Electrical, Fire Sprinkler, and Mechanical Engineers

16. Electrical Rooms – not the main electrical
  - a. All electric rooms to be separated from other spaces with a 1-hour fire-resistance-rated assembly and be equipped with fire sprinkler protection.
17. Chemical Science Storage Room
  - a. Provide layout and location accessible directly from lab.
  - b. Provide one-hour fire rated room (Floor, ceilings, and walls).
  - c. Provide for flammable storage cabinet(s) and if vented, vent directly to the exterior using materials equal to the cabinet.
  - d. Provide non-corrosive shelving with minimum ½ inches lip on shelves.
  - e. Provide sign in area near storage shelves, where user can readily see sign reading “STORE ALL FLAMMABLE MATERIALS IN FLAMMABLE STORAGE CABINET”.
  - f. Coordinate with Mechanical Design Criteria and Mechanical Engineer.
18. Science Room Emergency Shower/Eyewash
  - a. Provide layout and location within lab.
  - b. Slope floor to a floor drain.
  - c. Coordinate with Plumbing Engineer.
19. Administration Suite
  - a. Staff Mail Boxes
    - 1) Provide counter directly under the mailboxes.
    - 2) Set top most shelves at maximum 72 inches above finished floor.
    - 3) Provide area for large packages.
    - 4) Provide mail slots for staff.
  - b. Reception Area
    - 1) Coordinate the location of fire alarm, communication, and other electrical/electronic controls with the Electrical Engineer to provide necessary enclosures for conduits and boxes.
  - c. Separate the Administrative Suite from the Student occupied spaces with at least 1-hour fire resistive construction.
    - 1) Purpose is to allow the office doors within the Administrative suite to remain open during normal use.
20. Data/Communication Rooms
  - a. Main Data Room, Main Telephone Room, Communication Service Room and/or Communication Equipment Room, Data/Communication Rooms
    - 1) No ceiling in these rooms, open to structure above.
    - 2) Coordinate light fixture placement and fire sprinkler head coverage with location of equipment rack.
21. Shops
  - a. Provide specialty shops as outlined in the Ed Specs.
  - b. Plan for all specialty equipment and provide the necessary space, electrical connections, water and sewer connections, and special HVAC needs for the space.
  - c. If wood shop or similar dust producing shop provide:
    - 1) Exterior central dust collection system.
    - 2) A high efficiency filtration on the return air duct of the HVAC system for the wood shop, and independent of returns from other spaces.
    - 3) Portable dust collection systems may be used for small portable power tools like sanders.
22. Exterior Handrails

- a. Design the top rail component to deter sliding down the rail without preventing a continuous graspable surface.
    - 1) Shall meet the requirements of FBC.
- 23. Platforms and Stages
  - a. Provide stage or platform finished floor elevations at the following distances above the main floor:
    - 1) Elementary schools (cafeterias, multi-purpose rooms) = 18" min.
    - 2) Middle schools (cafeterias, multi-purpose rooms) = 30" min.
    - 3) High schools (auditoriums) = 40" min.
- D. CASEWORK/CABINETS
  - 1. Cabinets, locks and Casework; coordinate with the District Interior Design Coordinator.
  - 2. Base cabinet countertop heights in student occupied spaces shall be as listed in table for Mounting Heights in the appendix.
  - 3. All case work on exterior wall shall have a minimum ½ inch air space (1 inch is preferred) between back of casework and the finished wall.
    - a. Any counter top on the base casework shall extend to the wall to prevent paper and other materials from falling in the air space
    - b. Provide for ventilation of the air space.
    - c. Provide for closure of any side exposed to the room to prevent papers or other material from been placed behind the casework.
  - 4. All casework and cabinets shall be free of protruding sharp corners.
- E. THERMAL AND MOISTURE PROTECTION
  - 1. Waterproofing and Vapor Barriers
    - a. Waterproofing
      - 1) Provide waterproofing at floors and walls below grade to prevent water infiltration to the building interior caused by hydrostatic pressure or other water conditions. Elevator pits are included.
      - 2) Provide waterproofing at the inside face of planter walls or planter floors where the outside face is exposed.
      - 3) Do not use planters as part of a finished wall or ceiling assembly.
    - b. Vapor Barriers (including Radon Barriers).
      - 1) All vapor barriers on exterior walls shall be on the warm side, between the insulation and the exterior wall surface.
      - 2) Test the soil for Radon, if Radon found or suspected in the area:
        - a) Follow the Florida Standard for Radon-Resistant New Commercial Building Construction, or the EPA Handbook for Sub-Slab Depressurization for Low Permeability Fill Material.
        - b) As alternate remove the contaminated material.
      - 3) Provide details of perimeter, penetrations, and joint conditions.
      - 4) Under concrete slab-on-grade components use a 10 mil polyolefin or polyethylene vapor barrier system, including seam taping along sheet joints and pipe penetrations.
  - 2. Insulation
    - a. Select an appropriate and cost effective insulation system to comply with the FBC - Energy Conservation.
  - 3. Fireproofing and Fire stopping/fire blocking
    - a. Fireproofing and Fire stopping methods shall be per FBC and NFPA.
    - b. Provide descriptions and approval references for fire stopping systems used.

- c. Specify fire protection at penetrations through fire rated assemblies as required.
  - 1) Provide description, test number, and detail of code approved fire rated system for each type penetration.
- 4. Joint Sealers (Tilt-up Concrete Walls)
  - a. Tilt-up concrete wall panel joints:
    - 1) Exterior wall joints-Both sides (outside and inside)of exterior wall joint shall be sealed with an exterior joint sealant system, consisting of a foam backer rod placed into a clean joint cavity and covered with a urethane or other acceptable joint sealant material.
    - 2) Interior wall joints:
      - a) In fire resistance rated walls-maintain the fire resistance rating, seal both sides of joint, encapsulating the ceramic fiber blanket protection, similar to the exterior joint sealant system described in the previous item.
      - b) In non-fire resistance rated walls:
        - (1) Exposed concrete panel joints are to be sealed, including joints below coping caps.
        - (2) Concealed (furred) panel joints need not be sealed.
- 5. Roofing
  - a. General
    - 1) The Architect shall select the appropriate roofing membrane system for the project.
      - a) Acceptable systems include; Conventional Built-up Roofing Systems, asphalt shingles, and Modified Bitumen Roofing Systems.
        - (1) Gravel ballast systems are not allowed.
      - b) The preferred standard roof deck for new buildings is lightweight insulating concrete over galvanized metal support pans.
      - c) Metal roof systems
      - d) Asphalt Shingles (new installations and repairs):
        - (a) 2:12 minimum slope.
        - (b) Provide self-adhering ice and water barrier directly to roof sheathing, with a 30 pound roofing paper (use double underlayment) between the ice/water barrier and the asphalt shingles.
        - (c) Do not apply new asphalt shingles over existing asphalt shingles under any circumstances (repairs).
    - 2) Roof designs shall comply with the following.
      - a) UL-790 and ASTM E-108 requirements for Class "A" fire rating of roof coverings.
      - b) Uplift requirements based on the basic wind velocity pressures for the project according to the most stringent applicable requirements among the following.
        - (1) FBC chapter 16 and SREF section 453.
        - (2) ASCE 7 – latest edition as approved by FBC.
        - (3) Roofing manufacturer's specifications.
    - 3) SDPBC prefers one roofing system per campus; use of an additional roofing system requires approval on a per condition basis.
      - a) If using different roofing systems provide a parapet, change of elevations, or other means of terminations to define warranty/liability limits and maintenance concerns.
    - 4) Design the roof to eliminate ponding with sloping surface to remove rainwater and comply with the FBC - Plumbing.

- a) The use of flat roofs and interior roof drains is highly discouraged and requires prior approval via the variance process.
    - b) Provide roof drainage calculations, refer to the Appendix for an example.
  - 5) As part of the Design Development design review, the design team shall exhibit to the SDPBC PM methods for sequestering roof rain water discharge as part of overall site-wide storm water management strategy.
    - a) Connect all primary roof drainage systems to the storm water system.
    - b) Storm water system connections may be at above grade components, such as swales, ditches, or detention/retention basins.
  - 6) Products containing asbestos are not allowed (FBC – Building, 453).
  - 7) Traffic Pads shall comply with the following requirements.
    - a) Traffic pads to completely encircle/surround roof scuttles and roof-mounted equipment requiring routine maintenance.
    - b) Arrangement of traffic pads shall facilitate safe use by maintenance personnel.
    - c) Size traffic pad as necessary to facilitate maintenance of large pieces of equipment.
    - d) Clearly indicate traffic pad layout on the Construction Documents per 7 a) above.
  - 8) Design EHPA facilities with minimum Rooftop Mechanical equipment or fans.
    - a) Provide the appropriate wind and impact load protection for equipment on the EHPA roofs, which is readily removable by maintenance crews servicing the units.
    - b) Provide equipment tie-downs/curbs meeting the wind load and impact requirements of the FBC and ICC 500, entitled “ICC/NSSA Standard for the Design and Construction of Storm Shelters”.
- 6. Flashing, Gutters, Down Spouts, and Other Accessories
  - a. Flashing metal shall be 24-ga. stainless steel (22-ga. For structural supports), or 0.40 ga aluminum, complying with SMACNA and NRCA Roofing & Waterproofing Manual, unless thicker materials are required for wind resistance.
  - b. Scuppers, Gutters and Downspouts.
    - 1) Locate downspouts and scuppers to discharge in areas away from student traffic areas.
    - 2) Provide downspouts that are not climbable.
    - 3) Place downspouts in areas limiting exposure to hazards, such as lawn equipment, if not possible use materials resistant to physical damage from such equipment.
    - 4) Locate gutters at edge of roof perimeter; do not build gutters behind parapets.
    - 5) Coordinate connections of gutters, downspouts, and roof drains to the storm drain systems.
      - a) Provide gaps in gutters for roof access at appropriate locations, when applicable.
    - 6) Provide supports for to prevent downspouts from slipping and disconnecting at joints.
    - 7) Secondary scuppers shall be separate from the primary scuppers.
    - 8) Coping at parapet walls-use either pressure treated “nailer” or stainless steel metal clip system.
    - 9) Collector boxes shall be fabricated using only 300 series stainless steel.
    - 10) Downspouts can be made from stainless steel (24 ga), aluminum (0.40 ga min.), pvc (sch 40).
- 7. Roof Specialties and Accessories
  - a. Roof Expansion Joints.
    - 1) Allow for expansion and contraction to minimize cracking and deterioration of building component materials.

- 2) Provide roof expansion joints complying with NRCA Roofing & Waterproofing Manual and the roof manufacturer's requirements.
- b. Roof Scuttles and Roof Ladders
  - 1) Provide safe and secure access by scuttles, access hatches, or doors to each low-slope roof.
    - a) Access, by additional scuttle or access hatch or fixed ladders, is required to adjacent roofs if they are more than 42 inches above or below the accessible roofs.
    - b) Access hatch covers are required to meet wind loads and impact loads per chapter 16 FBC, can be PE certification or product approval system.
      - (1) Access hatch shall be min. 36" square and have a safety post to assist with roof access.
    - c) Provide for hatch-rail system per OSHA requirements around the roof opening.
      - (1) Use of fiberglass hatch rail systems is prohibited.
    - d) Do not use fixed external ladders from grade for roof access.

## F. DOORS AND WINDOWS

### 1. General

- a. Integrate doors and windows into the design of the facility to provide access, egress, light, and ventilation while:
  - 1) Meeting life safety, wind load, impact load and other code requirements
  - 2) Meeting concerns of vandalism and heavy usage.
  - 3) Incorporating safety, security, and maintenance concern

### 2. Doors and Frames

- a. Acoustical doors may be hollow metal or be solid core wood with STC ratings according to program requirements.
  - 1) Provide sound seals and drop seals, as necessary.
  - 2) Vision panels in acoustical doors shall be as tested and meet the safety glazing requirements of the FBC, except when other glazing is required to comply with fire rating.
- b. SDPBC strongly discourages the use of aluminum doors and doorframes (Store front systems); use of this type system requires prior approval via the variance process.
- c. Louvered doors shall be metal with protective coating to prevent corrosion.
  - 1) Full louvered doors shall have a mid-rail.
  - 2) Louvers to be V or Y-inverted profile, weather-resistant, and equal to thickness of door.
- d. Provide access doors of a size required by the code, equipment manufacturer, or type of access, but in no case less 12 inches x 12 inches where hand access is sufficient.
- e. In doorways or at doors of food service areas, provide 6 inches high stainless steel (spats) at doorframes with or without stops, (this is just Food Service area).
- f. Provide sound rated hollow metal doors at mechanical equipment rooms opening to the building interior; where possible open the mechanical door to the exterior of the building.
  - 1) Include sound-seals and aluminum thresholds at mechanical room locations accessed by interior corridors or adjacent to sound sensitive spaces.
- g. Fire and/or smoke separation doors.
  - 1) Provide magnetic hold open devices activated by the fire alarm system on doors dividing corridors and on doors in high traffic stairways.
- h. Doors, general



- 1) Exterior doors are to be metal with protective coating to prevent corrosion; do not use wood doors on building exterior.
    - a) Slope grade and sidewalk away from the building and the doors, minimum of 1% and maximum of 2% to prevent water from entering the build at the door openings.
  - 2) Interior doors may be solid wood or metal, but not particleboard.
  - 3) Occupant swing doors shall be a minimum size of 3 feet wide x 7 feet high x 1¾ inches thick.
  - 4) Doors shall be large enough to accommodate the largest piece of equipment or furniture scheduled for the space.
  - 5) Kitchen receiving door shall be 4 feet-0 inches wide x 7 feet-6 inches high x 1¾ inches thick with a 180° out-swing and 2 pairs of hinges.
  - 6) Provide a Dutch-Door for the laundry/towel room in P.E. locker rooms of Middle and High Schools, and in Early Childhood restrooms.
  - i. Interior or exterior pairs of doors shall be equipped with a removable mullion (between the doors), either keyed or non-keyed.
    - 1) Mullions are not preferred in mechanical and storage rooms.
    - 2) DO NOT use fixed mullions.
  - j. Vision Panels
    - 1) Provide vision panels at all doors entrances from corridors into classrooms, administration suite, laboratories, clinics, stairways, cafeteria, media center, other student occupied spaces as identified by the project team, smoke stop doors, door from media to the editing room at CCTV, door from classroom into toilet room vestibules, practice rooms at music suites, and other areas as required.
      - a) Vision panel shall be at least 6 inches wide and located 8 inches from latch edge of door.
      - b) Locate bottom of vision panels at 30 inches – 40 inches AFF and top at 72 inches AFF.
      - c) See [section G.5](#) "Glazing" of this document.
    - 2) Provide vision panels or glazed areas in doors at main entrances into the building.
    - 3) Provide vision panels in the doors and or wall between the kitchen manager’s office and the kitchen (considered hazardous locations require safety glazing).
      - a) Vision panel in door shall be top half of door.
      - b) Vision panel in the wall shall be 34 inches to 40 inches AFF and top at 72 inches to 84 inches width at 24 inches to 48 inches.
  - k. View ports
    - 1) Provide ½ inch diameter view ports with 180° view (peep holes), in place of door vision panels at the following locations.
      - a) Kitchen receiving door, also equipped with a doorbell.
      - b) Exterior entrance/exit doors without vision panels.
      - c) Comply with fire ratings.
  - l. Frames
    - 1) All door frames set in masonry or concrete walls shall be filled with grout.
    - 2) Interior door frames in partition walls shall be packed with sound insulation.
3. Windows
- a. Exterior Windows shall provide the following:
    - 1) Required light and ventilation per codes.
    - 2) Proper attachment/support system to withstand wind loads based on ASCE 7, and FBC.
    - 3) A passive system to meet the FBC and ASCE 7 requirement for impact protection.

- b. Accepted Windows.
    - 1) Operable Exterior Windows.
      - a) Single-hung or double-hung window.
      - b) Inward or outward-projecting window.
        - (1) Outward projecting windows are limited to areas where there is no pedestrian activity or to an elevation of 7 feet AFF.
        - (2) Inward projecting windows are limited to areas over fixed cabinetry or to an elevation of 7 feet AFF.
  - c. Maximum head height of windows shall not extend above the ceiling.
  - d. Provide insect screens only on operable windows in rooms designed for eating or cooking (Such as Kitchen, Cafeteria and Staff Dining).
  - e. The interior sill of a window shall not be below abutting built-ins or FF&E
    - 1) CCTV Control Room, observation fixed-glass window sill shall be 34 inches above finish floor.
  - f. Provide light control for room darkening for audiovisual presentations at instructional spaces one of the following methods at all windows.
    - 1) Vertical-blinds.
    - 2) Other systems accepted by SDPBC on a per condition basis.
    - 3) Curtains and window tinting are unacceptable sun control methods for room darkening in instructional spaces.
  - g. Mullions, if used, shall be integral with the window framing system and not surface applied.
  - h. Glazing shall comply with the requirements of FBC and these criteria.
    - 1) Design to minimize accidental passage through the glass (i.e. – rated safety glazing or equal).
  - i. Coordinate louver sizes and locations with typical window modulation wherever possible.
  - j. Storage rooms, telephone and electric closets, mechanical equipment rooms, toilet rooms, custodial closets, and other similar spaces shall be windowless.
  - k. Means of egress shall comply with FBC – Building and FFPC without compromising window security or aesthetics.
  - l. Indicate locations of fixed and operable window panels on Contract Document – Floor plans and elevations, coordinate with the window schedule.
  - m. Indicate location of Fire Department Access Panels on the Contract Document - Building floor plans and elevations, if required by code.
  - n. Interior observation windows:
    - 1) Teacher planning area
    - 2) Clinic, see prototype
    - 3) CCTV space, angle window 15° angled toward the studio.
    - 4) Other areas
  - o. Rough opening for window openings:
    - 1) Sill profile; the window sill profile shall be stepped or notched to create a natural water stop.
    - 2) Provide reveal on jambs and head of all window openings to accept window units with off-set flanges.
4. Finish Hardware
- a. Hardware shall comply with the following, which have precedence over SDPBC requirements.
    - 1) Florida Building Code, Building and Accessibility volumes.
    - 2) Florida Fire Prevention Code and NFPA 101 (the Life Safety Code).

- b. All hardware shall be consistent with the approved/tested door and window assemblies for impact, fire rating and wind loading.
- c. Hardware sets shall list the appropriate door and building number, the door schedule shall list the appropriate hardware set numbers, and hardware sets and the door schedule shall comply with:
  - 1) Each door or pair of doors, gate, roll-up grill, or other opening shall receive a different numerical designation with hand of each door noted.
  - 2) Door numbering should be progressive and according to walk paths.
  - 3) Specified hardware schedule shall note SDPBC project number.
- d. Latching Hardware.
  - 1) Do not use deadbolt locks except as permitted by code and with SDPBC approval.
  - 2) Provide surface mounted exit devices or classroom security function locks at student occupied areas according to FBC, FFPC and program requirements.
- e. Controlling Hardware.
  - 1) Do not use head or foot bolts on any pair of doors of student occupied spaces.
  - 2) Door Stops.
    - a) Install wall-mounted doorstops at all doors with appropriate backing reinforcement.
    - b) Avoid floor-mounted doorstops.
  - 3) Kick Plates.
    - a) Provide at all doors except to individual offices at administration areas.
    - b) Provide an armor plate at the kitchen receiving door and doors from kitchen to serving line.
      - (1) Armor plate shall be 32 inches high, min.
  - 4) Specify surface mounted door closers and exit devices, do not use floor mounted or concealed overhead closers.
  - 5) Use special delay action closers at doors serving children with disabilities.
  - 6) Select removable center hardware mullion type based upon exit device and fire rating requirement.
  - 7) Provide silencers or program required door seals on doorframes.
  - 8) Electrical Rooms, Mechanical Rooms & Outdoor Storage Rooms shall be equipped with closers and arm limiters/hold open devices.
  - 9) Provide door closers on all exterior doors.
- f. Weather Stripping and Seals.
  - 1) Provide bull nose tile, molded vinyl strip, or marble thresholds at group or single toilet rooms, wet mop rooms adjacent to other spaces, custodial closets with a sink or mop receptor, or any other space where there are two different floor coverings transitioning.
  - 2) Provide aluminum thresholds at interior accessed mechanical rooms for soundproofing and at exterior doors to prevent water intrusion except at gates, kitchen-receiving doors, and other programmed required locations.
    - a) Do not provide thresholds at interior doors unless required for soundproofing or carpet separation at labeled doors.
    - b) Thresholds at exterior doors shall prevent water intrusion of driving rains and/or rising water.
  - 3) Provide rigid weather-stripping at frames of all exterior doors.
    - a) Weather stripping at exterior doors shall comply with acoustical requirements.

- 4) Provide sound-seals and auto door bottoms at acoustical doors and sound sensitive areas.
  - a) Sound seals shall not protrude more than 3/8 inches from stop surface.
  - b) Sound sensitive areas include entrances to media center, auditoriums, band rooms, music suites, practice rooms, and CCTV rooms.
  - c) Coordinate with prototype rooms.
- 5) Provide rain drip or other door top protection at exterior doors without overhead protection for full doorframe width.
- g. Hardware Sets
  - 1) Meet the requirements of the FBC and the FFPC for operation.
  - 2) Hardware shall be compatible with existing schools.
  - 3) Locksets shall meet the District's master key system.
- 5. Glazing
  - a. Exterior glass shall be impact resistant and meet resist wind pressures of ASCE 7 and FBC.
  - b. Glazing in SDPBC buildings shall be safety glazing of tempered glass, laminated glass, or SDPBC accepted glass block.
  - c. Glazing in fire-rated doors and walls shall be:
    - 1) Fire-rated glazing.
    - 2) Safety glass (hazardous location).
  - d. Protect glass at all doors where push bar exit devices cross glazing.
  - e. Mirrors – refer to the toilet accessories section.
- G. FINISHES
  - 1. General
    - a. Provide finish materials durable and suitable for South Florida weather conditions.
    - b. Architect shall work with the District Design Coordinator on color selection for all finish material.
    - c. Finishes shall allow for easy cleaning of graffiti or stains by the custodial staff.
    - d. Base the design and selection of building finishes on the following.
      - 1) Vandal resistance
      - 2) Cost effectiveness
      - 3) Durability
      - 4) Resistance to cracking and peeling
      - 5) Resistance to fading or discoloration during use or from exposure to weather, or acids and other chemicals.
      - 6) Weather tightness under hurricane conditions.
      - 7) Absence of excessively rough or sharp textures and features.
      - 8) Do not use finish materials containing or emitting harmful substances into the air, after cured or during occupancy by students or staff.
        - a) Building products shall not contain asbestos.
        - b) Do not use building products containing lead, formaldehyde, mercury, volatile organic compounds, or any other harmful products that can cause harm to occupants once installed.
      - 9) Use materials that resist the growth of mold.
    - e. Do not use vinyl wall coverings on the interior surface of exterior walls.
  - 2. Floor Finishes
    - a. Select flooring finishes based on durability, initial costs, and maintenance methods/costs.
    - b. Required Minimum Slip Resistance Coefficients:

- 1) 0.5 – level floors.
  - 2) 0.6 – accessible routes.
  - 3) 0.8 – ramps, inclined floors, or walks.
- c. Polished concrete floors are an option the designer may consider in corridors, media center, main reception area, or other large general gathering areas, but not in the cafeteria.
- 1) Polished concrete floors must be pre-approved before inclusion in the design documents.
  - 2) Show a control joint plan for all polished concrete floors.
- d. Ceramic Floor Tile.
- 1) Provide ceramic tile floors in all toilet and shower areas.
  - 2) Recess floor slabs receiving ceramic tile the depth of the tile and setting bed to provide a level plane at access points.
    - a) Provide slabs with steel trowel and fine broom finishes no curing compounds.
  - 3) Provide a tile cove wall base at areas with a ceramic tile floor.
  - 4) Tile flooring shall be suitable for floor use and easily maintainable.
  - 5) Select color of tile and grout to conceal dirt for low maintenance, avoid very light colors and very dark colors.
  - 6) Specify epoxy grout for ceramic tiles.
- e. Quarry Tile, Epoxy Flooring, Urethane Flooring\*
- \*use any of these flooring systems in Kitchens, Culinary Art Labs, Custodial Receiving, Custodial Closets, Flammable Storage, and Chemical Storage Rooms in buildings located in Wellfield Zones as designated by Palm Beach County
- 1) Provide quarry tile, epoxy flooring, or urethane flooring in Kitchens and Culinary Arts Labs.
  - 2) Recess floor slabs receiving quarry tile the depth of the tile and setting bed to provide a level plane at access points.
    - a) Provide slabs with steel trowel and fine broom finishes no curing compounds.
    - b) Slab shall be level and have floor drains.
  - 3) Quarry tile shall be flat, impervious, slip resistant, and be easily cleanable.
  - 4) Provide 6 inches high quarry tile wall base to match floors.
- f. Resilient Flooring
- 1) Provide resilient tile in classrooms, corridors, music rooms, media center, teacher planning, administration area, reception area, cafeteria, custodial office communication service room, communication equipment room, main data room, or as directed by the project administrator.
  - 2) Resilient flooring may be vinyl composition tile.
  - 3) Solid color or surface pattern vinyl composition tile are not allowed.
  - 4) Provide metal edge guards at flooring transitions.
  - 5) Areas with resilient flooring shall receive rubber cove base. Job formed corners will be allowed subject to final inspection of the completed project.
  - 6) Interior stairs shall receive rubber nosing and treads.
    - a) Stair landings shall receive resilient flooring.
  - 7) Use of flooring shall be appropriate according to manufacturer's guidelines.
- g. Sheet Vinyl or Linoleum Flooring
- 1) Provide homogenous sheet vinyl or linoleum flooring in the Clinic and the gymnasium 1<sup>st</sup>-aid room.
  - 2) Run floor material up the wall 6 inches to form a cove base.

- h. Thin-Set Terrazzo Epoxy Flooring – Alternate
  - 1) May provide thin set terrazzo system in toilet, showers, drying rooms and kitchens in place of ceramic tile or quarry tile, if cost effective and pre-approved.
  - 2) Run coating 6 inches up walls to form cove base.
  - 3) Recess floor slabs receiving thin set epoxy.
- i. Carpet Tile
  - 1) Provide carpet tile only in the Principal's office.
  - 2) Carpet tile selection shall be a stable; even surface of tufted carpet, shag carpet or other irregular surfaces are not acceptable.
- j. Sealed Concrete Floors
  - 1) Provide sealed smooth finished concrete floors in Custodial Closets, Central Receiving, Kiln, Art, Career Academy Shops, Storage Rooms, Mechanical, Electrical, Data Communication, and other similar rooms.
  - 2) Provide a translucent, non-yellowing, resistant to moisture and efflorescence, with slip resistant per the general requirements, and does not emit toxins after curing.
  - 3) Use rubber cove wall bases at interior sealed concrete floors.
  - 4) Sealed concrete floors are not an impervious surface.
- k. Polished Concrete:
  - 1) Provide polished concrete floors in areas as selected by the Architect with the District's approval.
  - 2) Any patterns or stain colors are determined by the Architect with District input.
  - 3) Use rubber cove wall bases.
- l. Wood Flooring
  - 1) Provide wood flooring in the secondary school Gymnasium, Dance Lab, Secondary Music Suite, and Stage.
  - 2) Recess floor slabs receiving wood flooring the depth of the wood floor, sleepers, and pads to provide a level plane at access points.
  - 3) Provide tongue and groove, maple or oak wood over wood sleepers on cushioning pads.
    - a) Required pad thickness:
      - (1) Gymnasiums – 3/8 inch.
      - (2) Stage, Gymnastics/dance – 5/8 inch.
    - b) Use cove rubber bases or other base as recommended by flooring manufacturer.
    - c) Expansion joint covers shall be stainless steel and flush with flooring.
    - d) Where exterior door enter directly into the gymnasium, provide mats or dirt gratings for the full width of gymnasium entrance doors securely anchor to the floor.
  - 4) Provide expansion joints per the manufacturers recommendations, but do not allow correction rows.
  - 5) The SDPBC may consider other specialty types of flooring on a per project basis.
  - 6) Provide floor sleeves for volleyball net poles.
- m. Rubber or Vinyl Sports flooring
  - 1) May provide alternate rubber or vinyl sports flooring material in Middle School gymnasium.
  - 2) Provide rubber or vinyl sports flooring in weight rooms and fitness rooms with either a rubber or vinyl base.
- n. Urethane Concrete/Cement Flooring System
  - 1) Floor and base

- 2) For application in kitchens, custodial receiving, custodial closets
- 3. Wall Finishes
  - a. Select interior finishes based on required fire resistance ratings, acoustical qualities, initial costs, durability, maintenance methods, and maintenance costs.
    - 1) Knock-down wall finish is preferred in corridors, stairs, and other areas of long walls.
  - b. Standard Interior Wall Finishes.
    - 1) Paint all gypsum board walls with washable, graffiti and mold resistant paint.
    - 2) Painted concrete masonry units at interior locations.
      - a) Place conduit and plumbing lines within the block cores do not channel the wall face.
      - b) UL or STC masonry assembly rating provided to comply with applicable fire-resistive or sound rating requirements.
      - c) At interior exposed block at exterior walls.
  - c. Standard Exterior Finishes.
    - 1) Horizontal and vertical surfaces.
      - a) Two coat stucco over concrete/masonry.
      - b) Exterior 1/2 inch concrete board systems reinforced with vinyl-coated, woven glass-fiber mesh only at fascia's, soffits and other decorative elements.
      - c) Primer textured coating and paint over pre-cast concrete.
    - 2) Weather Protected Horizontal and Vertical Surfaces.
      - a) Stucco over expanded metal lath or paper-backed hot dipped galvanized welded wire fabric not part of the structural envelope.
    - 3) Exposed Concrete (i.e. tilt-up concrete wall panels).
      - a) Primer and Acrylic coatings.
    - 4) Strike final stucco coat to achieve score patterns, slope bottom edge of horizontal score lines to dispel water. Stucco reveals; at horizontal/vertical intersections, vertical reveals shall run through horizontal reveals.
    - 5) If brick is used, it shall be graffiti resistant and readily accessible for future replacement.
  - d. Ceramic Wall Tile
    - 1) Use on all walls in Group toilet rooms, group toilet room vestibules, showers/locker rooms, cafeteria kitchens, snack bars, salad bars, and serving areas. to a height of at least 60 inches with epoxy paint on the remainder of the wall.
    - 2) Use on walls behind water coolers, to a height of at least 60 inches with epoxy paint on the remained of the wall.
      - a) The entire wall surrounding a water cooler recessed into a niche will receive tile and epoxy paint per 2), above.
    - 3) Walls behind sinks in custodial closets shall be ceramic tile to a height of 6 feet-0 inches AFF and extend 12 inches min. to either side of sink.
      - a) Alternatives:
        - (1) FRP panel.
        - (2) Stainless steel panel.
        - (3) Alternatives must have sealed edges to prevent wetting behind the panel.
    - 4) In group toilet rooms, showers, and kitchens, use tile for the entire length and height of walls.
      - a) Height of tile may be reduced to six feet above the floor with pre-approval.
    - 5) Provide bull nose trim pieces at exposed corners of tile walls and cove bases at floor line.

- 6) Do not install ceramic tile over existing ceramic tile.
- 7) Apply tile over.
  - a) Cement board or paperless wallboard designed for use in wet areas and installation of tile in staff or individual toilet rooms.
  - b) Water resistant concrete backer boards or similar non-paper covered boards, reinforced with vinyl-coated, woven glass-fiber mesh in toilet rooms that include showers.
  - c) 2 coat cement plaster over metal lath or paper backed welded wire fabric at food service areas, showers/locker rooms, and public and group toilet rooms.
- e. Acoustically Absorptive Wall Panels.
  - 1) Use to achieve acceptable NRC and reverberation characteristics in cafeteria dining rooms, CCTV Labs, media centers, career labs (per Ed Specs), auditoriums, music rooms, and gymnasiums.
  - 2) Coordinate with the prototype rooms listed in the Ed Specs.
  - 3) Panels shall comply with flame-spread ratings.
  - 4) Provide concealed panel attachments.
  - 5) Fabric covered panels or any other acoustical treatment susceptible to damage in auditorium, cafeteria dining rooms, music rooms, media center, or any other student occupied spaces shall be at least 7 feet-0 inches AFF or installed with other means of protection.
- f. Window Sills
  - 1) Provide seamed-edge marble sills with a honed finish.
    - a) 5/8 to 3/4 inch thick, white Carrara or similar.
  - 2) If pre-approved and less expensive, a solid surface material may be used.
4. Ceiling Finishes
  - a. Standard Ceiling Finishes
    - 1) Lay-in acoustical panel suspended ceiling systems shall have humidity and mold resistant materials, tile and grid system.
    - 2) Do not use "Tegular" ceiling tile.
    - 3) Cafeteria kitchens shall have lay-in style ceiling with plastic coated washable surfaces.
    - 4) Salad bars, snack bars, and serving areas shall receive 2 foot x 2 foot lay-in vinyl faced gypsum panels, meeting USDA/FSIS requirements, with an aluminum capped or aluminum suspension system.
      - a) Paperless gypsum board is also acceptable.
    - 5) Showers, drying and locker rooms, kiln rooms, and any other high moisture content spaces shall receive epoxy painted cement plaster/metal lath ceilings.
    - 6) Staff, individual toilet rooms, and group toilet rooms may be paperless gypsum board ceilings with epoxy paint.
    - 7) Provide access panels through gypsum board and plaster ceilings in sufficient size, number, and location to above ceiling electrical, mechanical, or other elements requiring access.
    - 8) Use stucco for exterior soffits to protect from potential damage by weather, vandalism, or excessive wear.
    - 9) Receiving, custodial, electrical, telephone, and mechanical rooms or closets, unfinished rooms, and other similar spaces may have an exposed painted structure if allowed by fire codes.
  - b. Ceilings shall provide the required acoustical ratings for specific areas according to Design Criteria - General Considerations.



- c. Avoid the use of metal ceilings and metal soffits.
  - d. Lay out ceiling tiles to avoid perimeter units of less than 1/2 unit width.
5. Paint Finishes
- a. Proper paint and primer selection shall be the responsibility of the Architect.
    - 1) Paint shall be durable, washable, mold resistant, and appropriate for the application.
  - b. Specify a bonding type primer or acid etching for pre-stressed or other types of smooth concrete to obtain an adequate paint bonding profile.
  - c. Painting shall only proceed with the SDPBC, Architect, and paint manufacturer representative's written approvals allowing painting to begin.
  - d. Interior and exterior wall and trim paint finishes shall be graffiti resistant up to approximately 8 feet above adjacent grade or walking surface.
  - e. Avoid the use of colors affected by ultraviolet light.
  - f. DO NOT use lead-based paints or primers.
- H. SPECIALTIES
1. Instructional Boards
- a. Instructional boards include marker boards and tack boards.
  - b. Develop a schedule listing sizes, types, mounting heights and methods, colors, and other accessories to coordinate program requirements, built-ins, and FF&E locations.
  - c. Use "[Mounting Height](#)" table in the appendix and FBC for determining mounting heights for the instructional boards.
  - d. Instructional boards shall be at least 24 inches from room corners, if room size allows.
  - e. Mount projection screens per manufacturer's recommendations.
  - f. Provide proper wall construction/backing to support instructional board units.
  - g. Do not locate instructional boards on operable partitions, unless no other walls are available.
2. Toilet Partitions and Privacy Screens
- a. In-group toilet rooms, provide toilet partitions at each toilet, urinal screens at each urinal, and privacy screens at showers.
  - b. Toilet stall partitions, privacy screens, and urinal screens shall be solid plastic or phenol, providing a waterproof non-absorbent surface resistant to marking with pens, pencils, or other writing instruments (Graffiti resistant), edges machined to ¼ inch radius.
  - c. Toilet partitions, privacy screens, and urinal screens shall have pilaster floor mounts with overhead bracing, and full-length wall brackets.
    - 1) Wall brackets shall be stainless steel or aluminum.
    - 2) Overhead bracing shall have a metal anti-grip design.
  - d. Pilaster shoes shall be stainless steel or aluminum.
  - e. Top edges of compartment panels and doors shall be at least 70 inches AFF, the bottom edge not more than 12 inches AFF, and pilasters minimum 82 inches high.
3. Exterior Wall Louvers
- a. Wall louvers shall be integral to the exterior building design.
  - b. Provide fixed wall louvers of extruded aluminum that are impact resistant, and designed to resist ASCE 7 wind loads.
  - c. Wall louvers shall be weatherproof to control water intrusion into the building.
4. Flagpoles
- a. Provide 1 flagpole per site and comply with the following.
    - 1) Located near the main office (entry) of the school.

- 2) Exposed height shall be 35 feet.
  - 3) Design flagpole to withstand wind velocity pressures in ASCE 7.
  - 4) Provide a tapered, seamless aluminum pole with an internal halyard system.
5. Signs
- a. General
    - 1) The Architect shall develop a comprehensive master signage plan for the campus using a way finding approach incorporating CPTED concepts.
      - a) This includes signage for the site, interior and exterior building, and regulatory requirements.
    - 2) This signage program shall identify a standard graphic system for all signage, designed consistent and in conjunction with the project design concept.
      - a) Includes directing all users safely and clearly from the public road to appropriate parking and throughout the campus.
      - b) Once parked, provide visitors a layer of way finding information on the pedestrian level.
    - 3) A comprehensive sign program should foster safety, facilitate management of an area, provide a learning opportunity for visitors, and offer a positive image and identity.
    - 4) All signs shall focus on the needs of visitors or students and deliver their message through positive terminology.
    - 5) Signage shall comply with all codes and regulations, such as FBC, FFPC, and FDOT.
    - 6) The designer shall confirm building and room name and FISH numbering starting at Phase I drawings and completing by Phase III documents, work with the Educational Planner – Facilities Construction.
    - 7) Sign materials shall be impact, abuse resistant and exterior signs and mountings shall meet wind load requirements.
    - 8) All signs are to use International Standard Symbols to the greatest extent possible.
    - 9) The installed heights of signs not otherwise prescribed are to match the needs of the anticipated users – children vs. adults
    - 10) Visual Character Heights not otherwise prescribed:
      - a) Sign Height up to 6 feet - 1/8 inch per foot of anticipated viewing distance but not less than 5/8 inches
      - b) Sign Height 6 feet to 10 feet - 1/8 inch per foot of anticipated viewing distance but not less than 2 inches
    - 11) Show the locations, types, sizes, and quantity of identifying devices on construction documents.
    - 12) Provide signs at entrances to corridors indicating the rooms down that corridor.
  - b. Exterior Signs
    - 1) Coordinate all sign locations with required traffic site triangles.
    - 2) Provide off-site directional signs along the nearest intersecting street.
      - a) Provide in a different color than standard traffic signs, coordinated with municipal standards as applicable.
    - 3) Pedestrian oriented signs shall have text large enough to have readability from 20 feet.
    - 4) Dedication Plaque.
      - a) New schools and additions shall have an 18 inches x 24 inches cast aluminum or bronze plaque locate near the main administration entrance or appropriate addition entry, with the following features:

- (1) The names of the School Board Members and the Superintendent of Schools in office the day the construction contract was awarded
  - (2) The year the construction contract was awarded
  - (3) The name of the contractor and architect of record
- 5) School Name
- a) Provide 15 inches to 24 inches high letters cast in dark contrasting colors with the school name and 12 inches high address numbers located on elevation of the facility legible from the street.
    - (1) Coordinate font and height with the District's Educational Planner – Facilities Construction.
  - b) Multi-building campuses - provide signage on the exterior of buildings to identify the building name and number, coordinate with Educational Planner – Facilities Construction.
    - (1) When possible these signs shall be readily visible from the main visitor entrance.
- 6) Marquee Sign
- a) Marquee sign shall have approval from the planning and zoning authority having jurisdiction.
  - b) Provide for a 2-sided marquee type sign with the School name and address.
    - (1) Address numbers shall be at least 8 inches high.
  - c) Locate in prominent location perpendicular to the main street in front of the school site, coordinate with District's Senior Project Administrator.
  - d) Sign shall have provisions for electricity.
  - e) Provide electronic changeable sign for High Schools.
  - f) Specify the height of the marquee sign or electronic changeable sign so it is visible above the fence line and landscaping.
  - g) Controls for electronic (changeable) marquees shall be as specified by the District'
- 7) Parking Signage
- a) Provide aluminum signage for traffic control and parking spaces.
    - (1) Principal Parking
    - (2) Visitor Parking, sign each space
    - (3) Accessible Parking, sign each space
    - (4) Student Parking area, sign area
    - (5) Staff parking, sign the area
    - (6) Service Area, sign the area
    - (7) Carpool Parking, Electric Car Parking (if provided), sign each space
    - (8) No cell phone usage in parent pickup loop.
    - (9) Other areas as defined by the project
  - b) Refer to the Civil Design Criteria for traffic signage.
- 8) Security
- a) The campus shall be resistant to unauthorized intrusion at any time, yet provide for the entry of visitors through a control point during normal operating hours.
  - b) Provide perimeter signs prohibiting trespassing and loitering see s. 810 Florida Statutes.
  - c) Limit perimeter openings to those required for Life Safety conformance and necessary for independent public use of the project elements e.g. an auditorium, a gymnasium, media center.

- d) These entries should also be visually recognizable and inviting.
  - e) Coordinate required openings with security and surveillance system requirements.
- 9) Building Entries
- a) There shall be a single, central visitor entry to the facility.
  - b) This main entry shall be clearly visible and easily identifiable.
  - c) Directional signs shall be provided from all visitor access points.
- c. Interior Signs
- 1) General, coordinate all signage with the District's Educational Planner – Facilities Construction.
    - a) Accessibility signage, room identification, and life safety signage shall contain raised characters, Braille, and symbols, and be according to FBC and FFPC.
    - b) Raised image interior and exterior signage to include:
      - (1) Proportions, height, finish, contrast, and locations according to FBC - Accessibility.
    - c) Confirm building, room name, and numbering with Educational Planner – Facilities Construction, starting at Phase I drawings and completing by completion of Phase III documents.
  - 2) Directional
    - a) The signage system should provide directional signs placed at decision points where significant numbers of users have to make choices or change direction.
      - (1) Consideration should be given to coordinating signs by the use of unique shapes or colors linked to specific destinations.
    - b) Signs in corridors shall indicate directions to:
      - (1) special use rooms
      - (2) specific subject areas
      - (3) wings of the building
  - 3) Room Identification
    - a) Room names on signage of any classroom or laboratory shall be limited to CLASSROOM or LABORATORY, remaining spaces shall have names on signage according to FISH.
    - b) Identify all doors, exterior and interior with FISH numbers and space names.
    - c) Provide information for maximum occupancy signs with Phase III documents.
  - 4) Primary and Emergency Evacuation Signage
    - a) Provide such signage per District Standard, depicting floor plan with graphics and text, for contractor's installation, showing the primary and secondary evacuation routes from each space with an occupant load of 6 or more.
    - b) The routes of evacuation shall be indicated in contrasting colors and only indicate the evacuation route from the applicable space.
    - c) Orient the map so when facing the mounting wall adjacent to the room exit, the "you are here" graphic symbol/arrow will point up.
    - d) Text and numbers shall read from left to right.
    - e) Show route to exterior of the building then to gathering point on site.
    - f) Coordinate with School Police, Risk Management, District Architect – Facilities Construction, and school principal.
6. Lockers
- a. Types of metal lockers are located and specified according to program requirements.
    - 1) Sizes as specified in DMS.

- 2) In the main student corridors of middle and high schools, provide a number of lockers equal to the school core capacity.
    - a) Size of lockers is to be approximately 2 cu ft, minimum 2 tiers and maximum 3 tiers high.
    - b) 12 inches to 15 inches wide and deep.
    - c) 20 inches to 24 inches high
  - b. Provide a 4 inches high concrete curb for floor mounted locker units.
  - c. Provide sloped tops for locker units.
  - d. Island lockers in circulation corridors shall be limited to 4 feet-6 inches elevation (with the sloped tops).
  - e. Lockers shall have a finish that is:
    - 1) Long lasting.
    - 2) Resistant to heat, impact, and fading.
    - 3) Resistant to corrosion.
    - 4) Available in a variety of colors.
    - 5) Low maintenance and graffiti resistant.
7. Fire Extinguishers
- a. Locate fire extinguishers as required by codes and standards in corridors, public spaces, instructional spaces and other rooms near primary entrances.
    - 1) At instructional and staff spaces, low hazard areas, and other non-corridor/public spaces fire extinguishers may be wall-mounted with retention strap equipped bracket.
    - 2) In corridors and public/assembly spaces, provide semi-recessed or fully recessed cabinets with tempered glass panel doors.
      - a) Extinguisher cabinets in fire rated walls shall be fire rated.
    - 3) Mount at heights to comply with all codes, including FBC – Accessibility.
  - b. Life safety plans shall show the location of all fire extinguishers and fire blankets.
    - 1) Flammable areas (Either 2A-40BC or 40:BC).
      - a) Science laboratories
      - b) Automotive shops
      - c) Boiler rooms
      - d) Air handling unit rooms
      - e) Flammable liquid storage areas
      - f) Duplicating stations
      - g) Teacher lounges
      - h) Kitchens install type K extinguisher, for saponification of greases, within 15 feet of cooking equipment.
      - i) Electrical Rooms
      - j) Generator Rooms
    - 2) Hazardous areas (4A – 60:BC).
      - a) Woodworking and construction shops.
      - b) Storage rooms where wood or paper products are stored.
      - c) Portables
      - d) Golf cart storage area
    - 3) Low hazard areas (2A – 10:BC).
      - a) Corridors and remaining rooms.
      - b) Class A or B fire areas.

- 4) Electronic lab areas (carbon dioxide agent, Class C, (10:BC).
- 5) Provide fire blankets in laboratories and shops.
- 8. Metal Shelving
  - a. Metal shelving shall be clip-type adjustable shelving of modular unit construction on individual bolted frame assemblies with rimmed edge.
  - b. Attach fixed shelving units securely to walls, if freestanding to floors.
  - c. Provide blocking in walls as necessary.
- 9. Toilet Room Accessories
  - a. Group facilities
  - b. All fixtures and accessory components shall comply with the all applicable dimensional criteria in the FBC – Accessibility, as applicable within the group toilet room.
  - c. Provide surface mount stainless steel paper towel dispensers and soap dispenser near the sink.
  - d. Provide a sanitary napkin receptacle
    - 1) In female staff toilet rooms
    - 2) In student individual toilets
    - 3) In each female group toilet room, near the water closet in all schools.
  - e. Provide stainless steel grab bars with peened surfaces and flanges for exposed mounting at accessible toilets.
    - 1) Provide vandal resistant fasteners and backing in the partition or wall for sufficient anchoring to resist a 250-pound force applied from any direction.
  - f. Mirrors
    - 1) Mirrors shall be either tempered glass (provide permanent identification, by manufacturer on type glazing) or polished stainless steel, in student toilet and shower rooms.
      - a) Provide concealed theft proof mountings, proper anchoring, and wall backing according to manufacturer's requirements.
    - 2) Install mirrors at heights and sizes to comply with FBC – Accessibility.
    - 3) Mirrors in staff Toilet Rooms may be of glass installed to requirements of chapter 24 FBC.
    - 4) Mirrors in Dressing Rooms associated with Auditoriums, Dance Labs, and other student occupied spaces shall be safety glazing properly labeled in upper right hand corner.
  - g. Provide rod and heavy-duty white vinyl shower curtains with exposed fasteners in showers in private shower rooms i.e. clinic or coaches office restrooms.
    - 1) In locker room group showers use partitions where possible to create visual baffles to reduce the need for curtains.
  - h. Provide stainless steel bookshelf in student group toilet rooms and shower rooms.
- 10. Dust Control – Woodshops and Similar areas
  - a. In installations, provide central dust collection system in shops or laboratories with 5 or more machines and/or tools producing fine dust particles such as saw dust.
- 11. Wire Mesh Partitions and Doors
  - a. 1 ½" diamond mesh, 9 ga steel wire
  - b. Partitions and doors framed from cold-rolled channels
  - c. Provide locking hardware on swing doors
- 12. Operable Partitions
  - a. Installations shall include enclosures for operable partition panels when not in use
  - b. Above-ceiling tracks shall be equipped with a continuous acoustic barrier
  - c. Operable partition panel types shall be either; single, hinged paired, or continuous hinged
- 13. Water Coolers and Bottle Filling Stations

- a. As part of each "low-spout height" water cooler, provide a bottle filling station unit component. Both water cooler and bottle filling station unit shall dispense refrigerated, non-filtered water. Stand-alone bottle filling station units shall also dispense refrigerated, non-filtered water.

## I. EQUIPMENT

### 1. Appliances

- a. Provide appliances for each grade level as listed in [Appliance](#) chart of the appendix.
- b. All appliances should carry the most cost effective Energy Star™ rating possible.
- c. Provide shop drawings indicating location, type, manufacturers' name, model number, warranty, and installation instructions.
- d. Appliances shall conform to FBC, FFPC, and applicable FBC – Accessibility requirements.

### 2. Athletic Equipment

- a. Provide appropriate athletic equipment in areas per Education Specifications.
- b. Provide shop drawings indicating location, type, manufacturers' name, model number, warranty, and installation instructions.

### 3. Gymnasium Dividers

- a. Provide electrically operated roll-up type gymnasium dividers.
- b. Curtain shall have the following characteristics.
  - 1) Bottom 12 feet shall be an opaque solid vinyl coated polyester fabric.
  - 2) Upper portion shall be vinyl coated polyester mesh.
  - 3) Curtain shall have a self-extinguishing (UL) fire rating.
  - 4) Curtain shall be resistant to rot, mildew, and ultraviolet light.

### 4. Assistive Listening Systems

- a. Provide Assistive Listening System in all assembly areas per FBC – Accessibility.

## J. FURNISHING

### 1. Auditorium Seating

- a. Provide the required number of seats.
- b. Seating layout shall comply with the FBC and FFPC.
  - 1) Layout should provide optimize sight lines.
  - 2) Disperse accessible seating as evenly as possible.
  - 3) Stagger seating so there is an offset from seat in front.
- c. Provide upholstered seating with back and retractable seat cushions.
  - 1) Fabric shall be durable, easy maintenance, and have a Class 'A' ASTM E84 rating.
  - 2) Exposed metal parts shall have a smooth, durable, and cleanable finish.
  - 3) Provide for highly visible and tamper resistant seat and row numbering system.
  - 4) Provide certification that seats is designed and built:
    - a) To withstand 600-pound static load, laterally distributed 3 inches from the leading edge.
    - b) To the 300,000 cycle ASTM F851-3 oscillation test.

### 2. Telescoping Bleachers

- a. Provide telescoping bleachers in gymnasiums, with the seating capacity per Education Specs.
- b. Provide electrically operated bleachers with multi-tier rows of seat, deck and risers on interconnected retractable supportive understructure, wall attach.
  - 1) Locate the electrical disconnect in a readily accessible area, but not easily accessible to general public, coordinate with electrical engineer.
- c. Bleachers and installation shall comply with the FBC, FFPC, and NEC.
- d. Provide the number of wheel chair seating spaces as required by code.

## K. SPECIAL CONSTRUCTION

### 1. High School Stadiums

- a. Provide a rubberized track with the field event areas.
- b. Home-side seating area, 3000-seat capacity and visitor side 999-seat capacity.
  - 1) Steel structure with aluminum treads, riser, and bench type seating.
  - 2) Design the structural system to handle gravity and up-lift loads without a concrete slab under the entire bleacher area.
  - 3) Design the structure in compliance with structural requirements of the FBC and ASCE -7 using the geotechnical report information for designing the foundation.
  - 4) Life safety, exiting, accessibility requirements per the FBC and FFPC.
    - a) Provide a guardrail system with chain link fencing.
    - b) Provide concrete walkways from all exits.
    - c) On the Home side provide:
      - (1) Exit ramps and stairs.
        - (a) Provide one 6 feet wide ramp at each end; stairs near ramp are optional.
        - (b) Minimum three-11 feet wide vomitories evenly spaced along the intermediate cross aisle exiting to the rear of the bleacher consisting of stairs or ramps in each.
        - (c) Recommend providing one or two ramps equally spaced along the front of the bleachers depending on occupant load.
        - (d) Widths of the stairs and ramps are minimums; Designer shall provide widths as required by the FBC and FFPC.
      - (2) Provide intermediate cross aisle the entire length of the bleachers.
      - (3) All areas of bleacher shall be less than 200 feet from the end of exit (stair or ramp end).
      - (4) Provide non-combustible 8 foot x 30 foot modular press box, with a passenger elevator for exterior use.
        - (a) Design media viewing platform on the same level as the press box access ramp, between the elevator and the press box, provide appropriate guard rail system, minimum of 200 square feet.
        - (b) Provide water tight enclosures preventing rain driven water from entering the elevator shaft and cab for elevator at each floor.
          1. Vestibule at each floor, fully accessible, with emergency call feature at the press box level (area of rescue assistance).
      - (5) Provide for minimum 33-wheelchair spaces with companion seats.
        - (a) Provide at least 4 with up to 8 spaces on upper level with access to these seats directly off of the elevator, do not route through the press box.
        - (b) Provide access directly to the bleachers from the upper accessible seats without going through the press box.
        - (c) The number of wheelchair spaces above is based on 3000 seat capacity; adjust as necessary for actual seating capacity.
    - 5) Provide an enclosed elevated metal (steel frame, metal wall panel finish) press box, approximately 600 sf in area (no roof-top viewing capabilities).
    - 6) Provide an elevator to access the press box, provide an enclosed vestibule (at the press box level).
      - a) On the Visitor side provide three exit ramps.



- (1) Provide one 6 foot wide ramp at each end, stairs near ramp are optional.
  - (2) Provide an additional 6 foot wide ramp in the midpoint along the front of the bleachers with optional stairs.
  - (3) Widths of the stairs and ramps are minimums; Designer shall provide widths as required by the FBC and FFPC.
  - (4) All areas of bleacher shall be less than 200 feet from end of exit (stair or ramp end).
  - (5) Provide for minimum 13-wheelchair spaces with companion seats.
    - (a) The number of wheelchair spaces and ramps/stairs above are based on 999 seat capacity; adjust as necessary for actual seating capacity.
    - b) Architect shall coordinate location of lighting for all areas above and below the bleacher with the Electrical Engineer.
    - c) Areas under the bleachers which are not a hard surface, and have gravel or stone cover shall have system to keep people from accessing the gravel or stone material.
2. Portable Exterior Bleachers
- a. Provide non-combustible portable exterior bleachers in the areas and numbers required.
  - b. Design bleacher to meet the requirement of FBC, FFPC, and ASCE 7.
  - c. Each bleacher section shall be 15 feet long with 5 rows and have a maximum seating capacity of 50.
  - d. Provide for temporary anchorage of the bleacher to meet current wind load requirements.
  - e. Provide guardrail system with chain link fence fabric and supports integral with the bleacher frame.
  - f. Provide concrete slab for access and capable of accommodating a minimum of two wheelchair spaces per bleacher section. (2 spaces if 50 or less)

#### L. CONVEYING SYSTEMS

1. General
  - a. Regulatory requirements for passenger elevators.
    - 1) Florida Building Code – Building and Accessibility.
    - 2) Florida Fire Prevention Code.
    - 3) Bureau of Elevators of the Department of Business Regulation according to Chapter 399 of the Florida Statutes.
    - 4) National Electrical Code.
    - 5) Components, accessories, fabricated parts, and structure requirements shall comply with ANSI/ASME A17.1.
2. Passenger Elevators
  - a. 1) Hydraulic
  - b. 2) Electric Traction
  - c. Elevators in schools are not for general use, they are for:
    - 1) Those with disabilities preventing them from using stairs.
    - 2) Furniture and equipment transport, and custodians.
  - d. Locate elevator of multiple story schools in a central location, limit the use of multiple elevators.
  - e. Locate elevator in an area protected from the weather, especially driving rain.
    - 1) Locate the enclosure to keep rain, including wind driven rain from entering the shaft.
  - f. Design school elevators with the following.
    - 1) No corridor push-button switches.
    - 2) Provide for SDPBC electronic security swipe card system and key operation.
    - 3) Provide vandal-resistant push-button switches at cab interior.

- 4) Fire call key switch.
- g. Elevator pits shall be externally water proofed to control ground water entry and shall include the following.
  - 1) Sump pit with a metal cover.
  - 2) Metal ladder, if pit is deeper than 3 feet 0 inches.
  - 3) Two moisture-proof light fixtures per pit.
  - 4) One grounded duplex receptacle.
  - 5) No PVC or plastic pipes.
  - 6) Provide sump pump with discharge to an oil-water separator.
  - 7) Provide a high water alarm tied into EMS installed in the pit, coordinate with electrical engineer and district master specification requirements.
- h. Provide a vandal-proof emergency line-powered speakerphone inside the cab to comply with applicable codes and standards.
- i. Provide a 6 inches radius elevator alarm bell with weatherproof mounting at building exterior with an "Elevator Emergency" sign.
  - 1) Connect the bell to emergency power in the elevator machine room.
- j. Capacity
  - 1) Provide a 2500-# capacity elevator serving 2 or 3 stories.
- k. Cab Interior
  - 1) Comply with FBC – Accessibility for cab size and mounting height of controls.
  - 2) Elevator cabs shall have durable and low maintenance interior finishes.
- l. Elevator Machine Rooms (when required)
  - 1) Locate next to or near the elevator hoist way.
  - 2) Provide at least 7 feet 0 inches clear headroom.
  - 3) Provide adequate ventilation while maintaining required fire rating of enclosure.
- m. Exterior elevator hoist way shall have enclosed vestibules at each landing.
  - 1) Do not place pipes, ducts and conduits not required for elevator operation in the elevator machine room.
- 3. Wheelchair Lifts
  - a. Provide wheel chair lift in locations required by FBC – Accessibility, vertical or incline types.
  - b. Wheel chair lifts are installed only when ramps are impractical.
  - c. Pre-approval is required.

END OF SECTION

## SOUND RATINGS

	Art Room	Auditorium	Band/Orchestra	CCTV	Central Receiving	Choir/Music	Classroom	Conference Room	Corridors Stairs	Dining Areas	Exterior	Restrooms	Gym	Kitchen	Laboratory	Mechanical	Media Center	Office	Resource Rooms	Skills Lab/ESE	Teacher Planning
Art Room	50	60	60	60	50	60	50	50	50	50	50	50	60	50	50	60	50	50	50	50	50
Auditorium		60	60	60	60	60	60	60	60	60	60	60	60	60	60	60	60	60	60	60	60
Band/Orchestra			60	60	60	60	60	60	60	60	60	60	60	60	60	60	60	60	60	60	60
CCTV				60	60	60	60	60	60	60	60	60	60	60	60	60	60	60	60	60	60
Central Receiving					45	60	50	50	45	45	45	45	45	45	50	45	60	50	50	50	50
Choir/Music						60	60	60	60	60	60	60	60	60	60	60	60	60	60	60	60
Classroom							50	50	50	50	50	50	60	60	50	60	60	50	50	50	50
Conference Room								50	50	50	50	50	60	50	50	50	60	45	50	50	50
Corridors Stairs									45	50	35	45	45	45	50	45	60	45	50	50	50
Dining Areas										50	45	45	45	45	50	45	60	50	50	50	50
Exterior											--	35	35	35	50	35	60	45	50	50	50
Restrooms												35	35	35	50	35	60	50	50	50	50
Gym													45	45	50	45	60	50	50	50	50
Kitchen														35	50	45	60	50	50	50	50
Laboratory															50	50	60	50	50	50	50
Mechanical																35	60	50	50	50	50
Media Center																	60	60	60	60	60
Office																		45	50	50	45
Resource Rooms																			50	50	50
Skills Lab																				50	50
Teacher Planning																					45

**Notes:**

- Walls with STC rating of 45 or less require doors with STC rating of 25
- Walls with STC rating of 50 or less require doors with STC rating of 30
- Walls with STC rating of 60 or less require doors with STC rating of 40
- Doors into music suites shall have rating or arrangement per the prototype in the Ed Specs.
- Exterior windows shall have minimum STC rating of 35.

## MOUNTING HEIGHTS

(In Inches)

ITEM	Early Childhood Lab (Age 3-4)	Elementary	Secondary
		Pre-K through Grade 5 (Age 5-10)	Grades 6-12 (Age 11-18 & adults)
Display Cabinet (bottom)	26	34	39
Marker Board (bottom & chalk rail)	26	30	34
Classroom Work Counter (height)	26	30	34
Computer Counter (height)	26	30	30
Lavatory and Sink (to top)	25	30	34
Mirror (lower edge, maximum height)	29	34	40
Soap Dispenser (centerline of operating button or top of plunger)	28	32	36
Tack board (bottom)	26	30	34
Paper Towel dispenser (bottom)	27	32	36
Water Closet (top of seat)	12	15	17
Water Closet (rim of bowl)	11	14	16
Urinal (rim)	NA	15	15
Water Closet (centerline from side wall)	12	15	18
Toilet Tissue Dispenser (to outlet)	Min.12 inches above the top of grab bar Max. 48 inches AAF		
Grab Bar (height, <i>code tolerance</i> )	20	25 ( <i>18-27</i> )	33 ( <i>33-36</i> )
Water fountain – (spout height at outlet; common areas; ( <i>special/low/standing</i> ) <sub>(1)</sub> )	25	30 <sub>(1)</sub> /36/42	36/42
Water Bottle Filling Station Height to Operator Mechanism	36	40	44
Shower Seat (height)	12	15	17
Grab Bar (in shower, height)	20	25	33

**FOOTNOTES:**

(1) In elementary schools (grades Pre-K through 5<sup>th</sup>) provide a third water fountain at 30 inches (to spout) in such areas as the Cafeteria and Media Center.

### CEILING HEIGHTS AND TYPE

ROOM / SPACE NAME	CEILING HEIGHT	CEILING TYPE
Career Labs	Per Ed Specs	Acoustical Tile
Classrooms	9' AFF	Acoustical Tile
Music rooms	12' AFF, 9' above highest riser, or per Ed Specs	Acoustical Tile
Group toilets	9' AFF	Hard Surface
Cafeteria and other assembly areas	15' clear - minimum	Acoustical Tile
CCTV -ES	14' Minimum 12' to pipe rail grid	Acoustical Tile
CCTV – MS & HS	25' AFF	Acoustical Tile
Media Center	12' AFF	Acoustical Tile
Covered Play Area	14' Minimum AFF Maximum height 20'	Exposed structure
P.E. Locker rooms MS & HS	9' AFF	
Gymnasiums MS & HS	22' clear	Exposed structure
Art rooms MS & HS	12' AFF	Acoustical Tile
Art Room ES	9' AFF	Acoustical Tile
Other rooms	As appropriate for the use	As appropriate

## APPLIANCES

PRE-K AND ELEMENTARY SCHOOL APPLIANCES								
	Washer/Dryer	Washer/Dryer Lg. Cap.	Microwave	Microwave/Convection	Dishwasher	Refrigerator	Refrigerator with icemaker	Refrigerator - Under counter
Clinic							X <sup>1</sup>	
Custodial: Central/Workroom		X	X			X		
ESE-Combined Storage	X				X			X
Food Service Area	See SDPBC Food Service Department's Generic Specifications							
Media Center: Prof. Library/ Production			X				X	
Principal Conference Room			X					X
Production Work Room (Admin)			X			X		
Skills Lab – Science			X					X
Stage-Dressing Room (Office)			X					X
Teacher Dining			X			X		
Teacher Planning (Each)			X			X		

MIDDLE SCHOOL APPLIANCES													
	Residential							Commercial					
	Washer/Dryer	Range/Oven	Microwave	Dishwasher	Garbage Disposal	Refrigerator	Refrigerator with icemaker	Refrigerator Under counter	Washer/Dryer	Convection Oven	Refrigerator	Freezer	Icemaker
Clinic							X <sup>1</sup>						
Custodial: Central/Workroom	X <sup>2</sup>		X			X							
ESE-Combined Storage	X			X				X					
ESE-Functional Skills Lab/Apt	X	X	X	X	X		X						
Food Service Area	See SDPBC Food Service Department's Generic Specifications												
Media Center: Prof. Lib/ Prod			X			X							
Music: Band Teacher Planning							X	X					
PE Concession			X			X							X <sup>4</sup>
PE First Aid						X							X <sup>3</sup>
PE Laundry									X <sup>2</sup>				
Principal Conference Room			X					X					
Production Work Room (Admin)			X			X							
Science: Chemical Storage				X			X						
Science: Material Storage (ea)							X						
Teacher Dining			X			X							
Teacher Planning (ea)			X			X							
<b>Career Education</b>													
<b>Family &amp; Consumer Science</b>													
Culinary: Laundry Room	X <sup>2</sup>												
Culinary: Student Kitchen		X	X		X	X							
Culinary: Teacher Demo			X	X	X					X	X	X	X <sup>4</sup>
<b>Health Occupations</b>													
Lab/Classroom			X					X					
Storage			X	X			X						
Notes													
<sup>1</sup> Lockable													
<sup>2</sup> Large Capacity													
<sup>3</sup> 200 pound capacity													
<sup>4</sup> 400 lbs Capacity													

HIGH SCHOOL APPLIANCES														
	Residential									Commercial				
	Washer/Dryer	Range/Oven	Microwave	Dishwasher	Garbage Disposal	Refrigerator	Refrigerator with icemaker	Refrigerator Under counter	Beverage Cooler	Washer/Dryer	Convection Oven	Refrigerator	Freezer	Icemaker
Art	X													
Auditorium Concession			X								X <sup>1</sup>			X <sup>4</sup>
Clinic							X <sup>1</sup>							
Custodial: Central/Workroom	X <sup>2</sup>		X			X								
ESE-Functional Skills Lab/Apt	X	X	X	X	X		X							
ESE-Storage	X <sup>2</sup>					X								
Food Service Area	See SDPBC Food Service Department's Generic Specifications													
Media Center: Conference Room			X					X						
Media Center: Prof. Lib/ Production			X				X							
Music: Band Teacher Planning							X							
Music: Vocal Reference Room								X						
PE Concession			X			X			X					X <sup>4</sup>
PE First Aid						X								X <sup>4</sup>
PE Laundry									X <sup>2</sup>					
Principal Conference Room			X					X						
Production Work Room (Admin)			X			X								
Science: Chemical Storage				X			X							
Science: Material Storage (ea)				X			X							
Teacher Dining			X			X								
Teacher Planning			X			X								
<b>Career Education</b>														
<b>Agriscience</b>														
Laboratory		X	X <sup>6</sup>	X			X							
<b>Biotechnology</b>														
Chemical Storage												X <sup>5</sup>		
Laboratory			X <sup>6</sup>	X				X						X <sup>3</sup>
Material Storage			X <sup>6</sup>			X								
<b>Construction</b>														
A/C, Refrigeration & Heating														X <sup>3</sup>



HIGH SCHOOL APPLIANCES														
	Residential									Commercial				
	Washer/Dryer	Range/Oven	Microwave	Dishwasher	Garbage Disposal	Refrigerator	Refrigerator with icemaker	Refrigerator Under counter	Beverage Cooler	Washer/Dryer	Convection Oven	Refrigerator	Freezer	Icemaker
<b>Cosmetology</b>														
Laundry	X <sup>2</sup>													
<b>Equine/Pre-Vet</b>														
Laboratory			X <sup>6</sup>											
Material Storage			X <sup>6</sup>	X		X						X	X <sup>3</sup>	
<b>Family &amp; Consumer Science</b>														
Combo Lab														
Laboratory		X	X		X	X								
Laundry	X													
Teacher Demo			X	X	X					X	X	X	X <sup>3</sup>	
Culinary: Classroom				X	X					X	X	X		
Culinary: Laboratory			X		X					X	X	X	X <sup>4</sup>	
Culinary: Laundry	X <sup>2</sup>													
Early Childhood Ed Lab	X	X	X	X	X		X							
<b>Health Occupations</b>														
Lab/Classroom			X <sup>6</sup>					X						
Laundry	X <sup>2</sup>													
Practical Nursing Lab		X	X <sup>6</sup>	X		X								
<b>Marketing</b>														
School Store							X							
<b>Notes</b> <sup>1</sup> Lockable <sup>2</sup> Large Capacity <sup>3</sup> 200 lbs Capacity <sup>4</sup> 400 lbs Capacity <sup>5</sup> Freeze to -40° F – DC to research <sup>6</sup> Capability to Handle Tall Beakers														

## ROOF DRAINAGE CALCULATIONS/PROCEDURE

### Code references;

Florida Building Code – Building, 2020 (hereinafter FBC-B).

Florida Building Code – Plumbing, 2020 (hereinafter FBC-P).

American Society of Civil Engineers, Minimum Design Loads for Buildings and Other Structures, (hereinafter ASCE 7-10).

Refer to Chapter 8 and Chapter C8, Rain Loads.

### Assumptions:

- Projects located within Palm Beach County shall comply with provisions in Section 1611 – Rain Loads, FBC-B.
- Applicable on roofs with parapets or curbs above the mean roof level.
- Roofs shall be designed for the maximum possible depth of water that will pond thereon as determined by the relative levels of roof deck and overflow weirs, scuppers, edge or serviceable drains. Structural elements are assumed to be un-deflected unless the roof slope is less than  $\frac{1}{4}$ " per foot.
- In determining the maximum possible depth of water, all primary roof drainage means shall be assumed to be blocked. The design rainfall shall be based on the 100-year hourly rainfall rate, use Figure 1106.1, FBC-B 2020. Refer to Chapter 11, FBC-P; 1611.1, FBC-B; Section 8.4, ASCE 7-10. Use 4" per hour for this example. (Note: use 4.5" per hour for School District projects.)
- Minimum roof pitch  $\frac{1}{4}$ " per foot.
- Maximum allowable roof live load is 20 psf.
- Primary roof drain in this example is a conventional round (basket type) internal roof drain (vertical drain).

#### STEP 1 Determine roof area, either whole roof or largest roof zone

In this example, 50' x 50' roof, with a 1' high parapet all sides.

Parapet: 50' x 1' x 4 sides = 200 sf/2= 100 sf vertical surface area impacting horizontal area (use 50% of contributing vertical surfaces)

**Total Roof: 50' x 50' = 2,500 sf + 100 sf = 2,600 sf total roof area (for flow calculations)**

#### STEP 2 Determine the amount of rain water falling on that roof area in GPM

Roof Drain Flow Rate (gpm) = area, (sf) x rainfall rate, (in/hr) x 0.0104

0.0104 is derived by taking 144 cubic inches of water (12" x 12" x 1") and dividing by 231 cubic inches of water in a gallon of water and dividing by 60 minutes, (144/231)/60 = 0.0104

**2,600 sf of roof area x 4" x 0.0104 = 108 GPM (rate of rainfall being accumulated)**

#### STEP 3 Determine type, number, and size of PRIMARY DRAIN(S) to discharge rainfall rate in gpm

In this case select a round roof drain and try a single drain

Refer to Table 1106.2, FBC-P, see ATTACHMENT 1

4" round, vertical drain has a 160 gpm capacity, OK, 160 gpm > 108 gpm

**Thus, a single 4" primary drain should work for the given roof area**

#### STEP 4 Verify the hydraulic head at the primary drain

Refer to Table C8-1, ASCE 7-10 and find the hydraulic head, see ATTACHMENT 2.

4" round drain with a hydraulic head of 2" flows 170 GPM-too much.

4" with a hydraulic head of 1" flows 80 GPM, not enough so interpolate.

4" with a hydraulic head of 1.31" flows 108 GPM, this will work.

**So, at design capacity there will be 1.31" of water over the drain to achieve design flow.**

Maximum live roof load is limited to 20 psf, as noted in the assumptions.

1.31" of water will weigh: (1.31" / 12" per foot) x 62.4 lb per cu. ft. = 6.81 psf

6.81 psf < 20 psf, **OK, 4" primary roof drain will work.**

**STEP 5 Establish the elevation of secondary/overflow scupper(s)**

Per 1108.2, FBC-P, Separate systems required-secondary roof drain system shall have the invert elevation offset from the hydraulic head (HH) elevation established for the primary roof drain system (recommended to be a maximum of 1”).

In this case we can take the 1” offset to set the invert elevation of the secondary drain(s).

Thus in terms of vertical elevations, 0” (base elevation of primary drain) +1.31” (HH for primary drain) + 1” (offset) = **2.31”**, **the actual elevation of the secondary scupper.**

This information is graphically shown in Attachment 4.

**STEP 6 Determine type, number, and size of SECONDARY DRAIN(S)-Round roof drain or scupper.**

In accordance with Section 1108, FBC-P, when sizing the secondary roof drain system the flow through the primary system shall not be considered. So, the secondary roof drain must be able to discharge the full design flow rate (i.e. 108 gpm) if the primary drain is plugged.

Two options are available for the secondary drain, a round roof drain or scupper, see below.

**OPTION 1 – ROUND ROOF DRAIN**

Try a single drain. Already know that a 4” vertical roof drain works as the primary drain.

So, verify head above roof level for a 4” round roof drain as the secondary drain.

Already know that the hydraulic head over the 4” drain is 1.31”.

Already know that the invert of the secondary drain is 2.31” above the roof level.

So total head for the 4” secondary drain = 2.31” + 1.31” = 3.62”

3.62” of water will weigh: (3.92” / 12” per foot) x 62.4 lb per cu. ft. = 18.82 psf

18.82 psf < 20 psf, **OK, 4” secondary roof drain will work.**

(Reviewing the dimension string: Base elevation of primary drain = 0” + 1.31 (HH for primary drain) + 1” (max. offset) + 1.31 (HH for secondary drain) = 3.62”-water depth at secondary)

(This information is graphically shown in Attachment 4.)

**OPTION 2 – SCUPPER TYPE ROOF DRAIN**

Refer to ATTACHMENT 2. Interpolate table to determine HH at actual flow rate.

Try a 6” wide x 4” high closed scupper. At 4” HH discharges 140 gpm, OK > 108 gpm.

As above, Option 1, check roof load at total HH. Interpolate table to get head for 108 gpm.

Total head for the 4x6 closed scupper is 2.31” + 3.36” = 5.67”

(5.67” / 12” per foot) x 62.4 lb per cu ft = 29.48 psf, > 20 psf (max). NO GOOD!

Try a 24” wide x 4” high closed scupper. At 1” HH discharges 72 gpm, at 2” HH discharges 200 gpm.

Interpolate, HH = 1.28” at 108 gpm.

Total head for the 4x24 closed scupper is 2.31” + 1.28” = 3.59”

(3.59” / 12” per foot) x 62.4 lb per cu ft = 18.66 psf.

18.66 psf < 20 psf, **OK, 4”x24” closed scupper will also work.**

**RESULTS:**

A single 4” primary roof drain set a 0” elevation (datum)

And either

**OPTION 1** - A single 4” secondary or overflow roof drain set at 2.31” elevation (datum).

(Refer to Attachment 4 for illustration)

Or

**OPTION 2** - A single 24” wide x 4” (min.) closed scupper whose invert elevation will be set at 2.31” (datum).

(Refer to Attachment 3 for illustration)

**ATTACHMENT 1**  
**Table 1106.2 - FBC-P**  
**STORM DRAIN PIPE SIZING**

PIPE SIZE (Inches)	CAPACITY (gpm)				
	VERTICAL DRAIN	SLOPE OF HORIZONTAL DRAIN			
		1/16 Inch per foot	1/8 Inch per foot	¼ Inch per foot	½ Inch per foot
2	34	15	22	31	44
3	87	39	55	79	111
4	180	81	115	163	231
5	311	117	165	234	331
6	538	243	344	487	689
8	1,117	505	714	1,010	1,429
10	2,050	927	1,311	1,855	2,623
12	3,272	1,480	2,093	2,960	4,187
15	5,543	2,508	3,546	5,016	7,093

For SI: 1 inch = 25.4 mm, 1 foot = 304.8 mm, 1 gallon per minute = 3.785 L/m

**ATTACHMENT 2**  
**Table C8-1, ASCE 7-10**  
**Flow Rate, Q, in Gallons per Minute of Various Drainage System at Various Hydraulic Heads, d<sub>h</sub> in Inches (Factory Mutual Engineering Corp. 1991)**

Drainage System	Hydraulic Head, d <sub>h</sub> , in.									
	1	2	2.5	3	3.5	4	4.5	5	7	8
4 in. diameter drain	80	170	180							
6 in. diameter drain	100	190	270	380	540					
8 in. diameter drain	125	230	340	560	850	1,100	1,170			
6 in. wide, channel scupper <sup>(b)</sup>	18	50	(a)	90	(a)	140	(a)	194	321	393
24 in. wide, channel scupper	72	200	(a)	360	(a)	560	(a)	776	1,284	1,572
6 in. wide, 4 in. high, closed scupper <sup>(b)</sup>	18	50	(a)	90	(a)	140	(a)	177	231	253
24 in. wide, 4 in. high, closed scupper	72	200	(a)	360	(a)	560	(a)	708	924	1,012
6 in. wide, 6 in high, closed scupper	18	50	(a)	90	(a)	140	(a)	194	303	343
24 in. wide, 6 in. high, closed scupper	72	200	(a)	360	(a)	560	(a)	776	1,212	1,372

Footnotes:

- (a) (Linear) Interpolation is appropriate, including between widths of each scupper.
- (b) Channel scuppers are open topped (i.e., 3-sided). Closed scuppers are 4-sided.

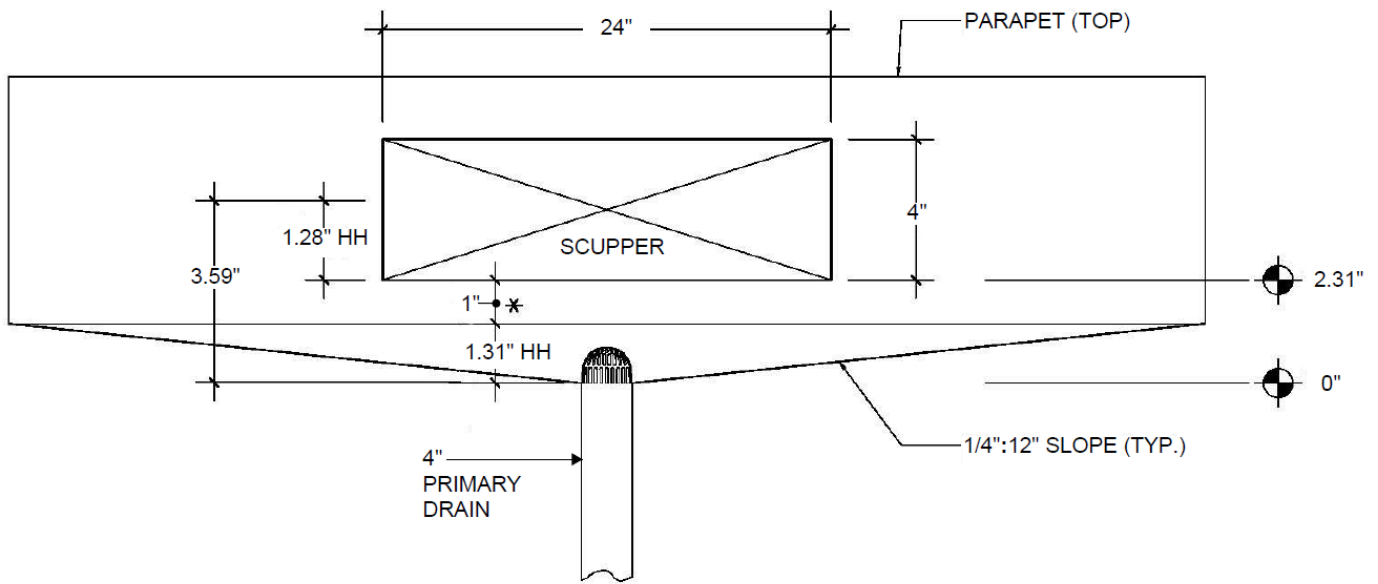

**SECTION ROOF SLOPE / SCUPPER BEYOND  
ATTACHMENT 3**

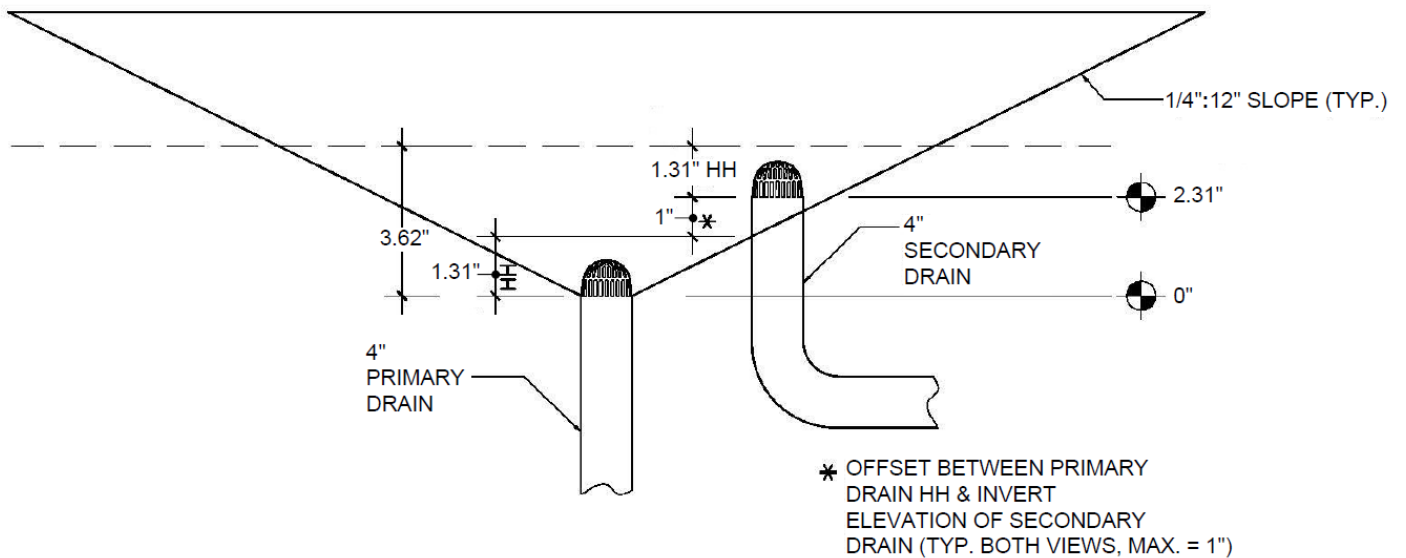

**SECTION ROOF SLOPE  
ATTACHMENT 4**